

INDEX – RIFLE

First Shot Fundamentals.....	Pages 1A-1B
Targeting 4-H Life Skills.....	Page 2
Lesson 1- Introduction to Rifle– First Shot Fundamentals	Page 3
Introduction, Safety, Eye Dominance, First Shot Fundamentals, Parts of the Rifle, Rifle Sights, Narrative	
Rifle Action Types.....	Page 16
Lesson 2-Dry Firing on Target Backs	Page 23
Sight Alignment, Trigger Control, Range Introduction, Range Safety, Range Commands, Basic Rifle Operation, Coach-Pupil, Dry Firing, Dry Firing at Target Backs, Bench Rest Position, Dry Firing from Bench Rest, Summary Narrative	
Lesson 3-Shooting for Groups on Target Backs.....	Page 35
Review, Repeat & Review Dry Firing, Live Firing at Target Backs, Live Firing at Target Backs, Evaluating Groups Narrative	
Lesson 4-Teaching Sight Picture.....	Page 43
Review, Learning Sight Picture, Live Firing at Target Faces, Developing Consistent Sight Picture, Sight Adjustment, Summary Narrative (See Supplemental Sheets for additional information on Sight Alignment, Sight Picture)	
Lesson 5-Shooting for Scores & Scoring Targets	Page 53
Review, Review Sight Picture & Sight Adjustment from Bench, Shooting for Score, Scoring Targets Narrative	
Lesson 6-Shooting Positions –Standing.....	Page 59
Narrative	
Lesson 7-Shooting Positions-Kneeling	Page 66
Narrative	
Lesson 8-Shooting Positions-Sitting.....	Page 72
Narrative	
Lesson 9-Shooting Position-Prone.....	Page 78
Narrative	

FACT SHEETS

Fact Sheet 3-Determining Eye Dominance.....	Page 85
Fact Sheet 4-Non-Threatening Hands-on Instruction.....	Page 90
Fact Sheet 5-Trajectory and Trajectory Experiments.....	Page 91
Fact Sheet 16-Pistol & Range Commands.....	Page 96
Fact Sheet 17 - Rifle and Pistol Shooting Procedures.....	Page 98
Fact Sheet 19-Trigger Squeeze (Press).....	Page 101
Fact Sheet 20-Penetration and Shock Demonstrations.....	Page 102
Fact Sheet 22-Air Gun Range Setup.....	Page 103
Outdoor Range with Berm, Target Stand 5 Meter BB Gun Back Stop	

SUPPLEMENTAL SHEETS

Hints for Sight Alignment & Sight Picture.....	Page 109
Fundamentals of the Shot.....	Page 128
Natural Point of Aim.....	Page 131
A Perfect Bull.....	Page 132
Sight Adjustment Exercise.....	Page 138
Basic Rifle for the Dumbfounded by Terry Abbott.....	Page 139

S.T.E.M. Connections

Rifle - First Shot Fundamentals - Revised February 2017 –

Included in Lesson 1 –

Time Approximately 1 hour

Welcome to 4-H Rifle

Share Restrooms Location

Share Classroom Procedure

1. Rifle Nomenclature and Safe Gun Handling Rules

- a. **Stock and forearm-** the parts of the gun that you grip
 - i. Explain how you grip the gun to shoot and carry in a safe manner (muzzle up with two hand grip)
- b. **Barrel Muzzle** – Front of the Barrel

KEEP THE MUZZLE POINTED IN A SAFE DIRECTION AT ALL TIMES!

- c. **Action** – The parts that load, fire and unload the gun

ALWAYS KEEP THE ACTION OPEN AND UNLOADED UNTIL YOU ARE READY TO SHOOT

- d. **Trigger** – That part of the action that releases the firing mechanism

ALWAYS KEEP YOUR FINGER OFF THE TRIGGER UNTIL YOU ARE READY TO SHOOT

- e. **Safety** – on when red not visible, mechanical device can fail
- f. **CBI** – (Clear Bore Indicator) is visible from the muzzle and action (explain why)

2. M.A.T – Three Fundamental Rules of Gun Safety

- a. **Muzzle** Always Pointed in Safe Direction
- b. **Action** Always Open, Empty and Exposed to View Until Ready to Shoot
- c. **Always Keep Your Finger Off the Trigger** Until Ready to Shoot

3. EYE AND EAR PROTECTION

Safety glasses Are **ALWAYS REQUIRED** in front of the safety line, ear protection required on rim-fire rifle

4. EYE DOMINANCE

- a. Check eye dominance
- b. Explain why it is important

5. BASIC SIGHT ALIGNMENT

- a. Explain type of sight used today
- b. Front sight and rear sight, (explain sight alignment) focus on front sight equal light on both sides of front sight in rear sight and flat across the top.
- c. Basic sight picture, front sight, rear sight, target, pumpkin on a post

6. CEASE FIRE COMMAND

- a. **ANYONE**, can call it (it is every one's duty to be safety conscious)
- b. Repeated by **EVERYBODY**, when called
- c. **STOP** what you are doing **IMMEDIATELY**, keep pointed in safe direction, open action, wait for further instruction

7. Fire Live Rounds at blank target backs from bench rest position rifles on bench, coaches load and charge rifles. A good practice is for instructors to provide a familiarization period where students are allowed to handle rifles and become familiar with the rifle parts, feel and operation. (See Lesson Narrative...First Shot Fundamentals-Firing the First Shot) This may also include a dry firing experience under direct and immediate supervision of instructors.

a. **RANGE COMMANDS** (Use enhanced Range Commands)

1. RANGE IS HOT
2. SHOOTERS TO THE LINE – assume shooting position
3. IS THE LINE READY
4. PLEASE RESPOND BY POSITION
5. THE LINE IS READY
6. COACHES REMOVE CBI
7. CHARGE OR PUMP THE RIFLE
8. LOAD THE ROUND
9. CLOSE ACTION
10. PLACE RIFLE IN POSITION ON SHOULDER FOR SHOOTER
11. TAKE OFF SAFETY
12. ALIGN SIGHTS AND OBTAIN SIGHT PICTURE
13. FIRE WHEN READY
14. PUT ON SAFETY
15. OPEN ACTION
16. REPEAT STEPS 7-15 AS NEEDED
17. CEASE FIRE
18. MAKE RIFLES SAFE, ACTIONS OPEN, SAFETY ON, CBI IN PLACE, GROUNDED OR BENCHED WITH THE MUZZLE IN A SAFE DIRECTION, ACTION EXPOSED TO VIEW
19. RANGE IS SAFE
20. YOU MAY GO DOWN RANGE AND RETRIEVE YOUR TARGET AND IF NECESSARY REPLACE IT WITH A NEW TARGET

8. Wash hands to remove lead residue from ammunition

9. Debrief and review



Iowa State 4-H Youth Development
 – Targeting Life Skills Model
 Reprinted by Permission Iowa State
 University

Introduction to the Rifle - First Shot Fundamentals

William F. Stevens, John Kvasnicka, Ronald A. Howard Jr., and Marilyn Bergum

Objectives

Participating youth and adults will:

1. Understand basic firearm safety.
2. Utilize eye and ear protection.
3. Recognize and identify the basic parts of a rifle.
4. Understand the functions of those parts.
5. Understand how to use different types of sights.
6. Determine their eye dominance.
7. Understand the basics of range rules and etiquette.
8. Understand sight alignment.
9. Understand sight picture.
10. Safely fire their first shot – **First Shot Fundamentals**.
11. Have fun while learning.

Roles for Teen and Junior Leaders

- Demonstrate equipment and how it functions.
- Assist with eye dominance exercise.
- Demonstrate range behavior and etiquette.
- Present selected parts of the lesson.

Parental Involvement

- See Roles for Teen and Junior Leaders above.
- Act as assistant instructors or range personnel.
- Arrange for or provide transportation.
- Arrange for or provide refreshments.
- Discuss personal experiences as appropriate.

Best Time to Teach

Any time of the year

Best Location

Classroom/range

Time Required

About 1 1/2 hour

Materials/Equipment

- flip chart or chalkboard and appropriate writing materials
- wooden sight blocks
- cardboard cutouts of different front and rear sights
- paper towel tubes
- sights attached with Velcro to PVC pipe
- telescopic sight
- rifles
- open bolt indicators
- appropriate ammunition
- blank paper or rifle targets
- eye/ear protection
- shooting benches or tables
- chairs
- sandbags or rifle rests
- staple gun, tacks, tape to mount targets
- rifle rack

References

NRA Junior Rifle Shooting. G Anderson, National Rifle Association, Washington, DC 1983.

The NRA Junior Rifle Handbook. G. Anderson,

* Conservation Affairs Manager, Federal Cartridge Company, Anoka, MN; Executive Director, Minnesota Deer Hunters Association; 4-H Youth and Development Specialist, Texas Agricultural Extension Service; National Rifle Association Field Representative, Minnesota, North Dakota, South Dakota

Teaching Outline

Presentation

I. Introduction

- A. Introduce facility and rules
 - 1. Food and drink
 - 2. Time schedule
 - 3. Discipline and courtesy
 - 4. Safety
 - a. Eye protection
 - b. Ear protection
 - c. Common sense
 - d. Personal responsibility
 - 5. Range Etiquette
 - 6. Firing line
- B. Review basic safety rules - MAT
 - 1. Muzzle control
 - 2. Action open
 - 3. Finger off trigger

II. Eye Dominance

- A. Determine eye dominance
- B. Importance of good shooting
 - 1. Use dominant eye
 - a. reduced eye fatigue
 - b. reduced tension
 - c. quicker target acquisition
 - 2. Both eyes open
 - a. reduced eye fatigue
 - b. better depth perception
- C. Coping with cross-dominance
 - 1. Eye dominance and hand dominance on opposite sides
 - 2. Learn to shoot from dominant- eye side
 - a. reduced strain on eyes
 - b. manual dexterity easier to teach
 - c. may require one-eyed shooting (rarely)
 - d. blinders
 - e. spot on shooting glasses

III. First Shot Fundamentals

- A. Basic parts of the rifle
 - 1. Stock-allows shooter to control the rifle
 - 2. Action -consists of firing mechanism, trigger, and safety.

Application

INTRODUCE facility and any specific rules for using it. If possible, provide written rules for review at home.

STRESS necessity of eye and ear protection for all shooters and spectators when using firearms. Ear protection may not be needed in some situations using air guns.

STRESS personal responsibility for shooting safety, authority of range officer and common sense.

ASK participants to list some basic rules for safe shooting.

RECORD answers to STRESS fundamentals for range sessions.

HAVE participants pair up and determine their eye dominance (see *Fact Sheet 3: Determining Eye Dominance*).

DISCUSS reasons for learning how to shoot with dominant eye even if it means relearning.

USE an unloaded rifle, poster or other illustration to POINT OUT and DISCUSS various parts of a firearm.

POINT OUT parts of stock and ILLUSTRATE how they function.

3. Barrel-provides a method for directing the projectile toward the target
- B. Sight Alignment
 1. Rear Sight
 2. Front Sight
 - C. Sight Picture
 1. Rear Sight
 2. Front Sight
 3. Target Back
 - D. Range Rules - basic rules needed to get off the first shot
 1. Basic range procedures
 - a. Range officer in charge at all times
 - b. Safety first
 - personal responsibility
 - eye and ear protection required of everyone on the range
 - No nonsense on range
 - No disruptive or abusive behavior
 - on the range
 - near the range
 - c. Any special circumstances
 - Basic rifle safety on the range
 - d. Muzzle pointed down range
 - e. Action open and empty except when firing
 - exposed for inspection
 - closed means ready to fire
 - f. Finger off trigger except when firing
 - g. Procedure if problem occurs
 - cease fire if necessary
 - keep rifle pointed down range
 - raise hand for help
 - h. Range commands
 - Shootersto the line”
 - “Is the line ready? Respond by firing point number”
 - “The line is ready”
 - “Pick up your rifles” (or make ready)
 - “Commence firing”

ASK participants why three major contact points for rifle are important to good shooting.

DISCUSS significance of support in precise shooting.

USE several comb designs (if available) to show how they aid in sighting.

DEMONSTRATE how butt spreads recoil.

- "Cease fire"
 - immediate response
 - each shooter's right /responsibility
 - end of stage or unsafe condition
- "Make the line safe"
 - safety on
 - open action and insert open bolt indicator
 - remove all ammunition
 - place rifle on mat or bench
 - muzzle down range
 - action open, empty, exposed to view
- Shooting at Target Backs - make sure equipment and range is ready prior to start of class
- Have each shooter fire five shots at a target back or blank paper
- Remove shooters from firing line, have them wash hands, continue with more in-depth instruction about the rifle.

IV. Orientation to the rifle

A. Stock

1. Primary functions
 - a. grip or handle
 - b. control
 - c. recoil distribution
2. Forearm (forend, fore stock)
 - a. non-dominant hand grip and control
 - b. support and orientation of barrel
3. Grip (wrist, small or pistol grip)
 - a. dominant hand grip
 - b. location and orientation of trigger hand
4. Butt stock
 - a. comb
 - cheek rest
 - orients eye with sights
 - b. butt
 - supports rifle on shoulder
 - spreads recoil energy

B. Action

1. Operating parts of rifle
2. Bolt or breech block
 - a. holds projectile in place
 - b. may cock action
 - c. ejects spent cartridge
3. Trigger
 - a. releases mechanical parts of the action causing rifle to fire
 - b. firing pin or hammer
 - c. air charge
4. Safety mechanism
 - a. mechanical device to block operation of the action
 - trigger only
 - trigger and firing pin
 - b. potential for failure
 - c. shooter ultimately responsible for safety
 - muzzle pointed in safe direction
 - personally check safety of any shot before firing

C. Barrel

1. Primary function – launching tube for projectile
2. Chamber
 - a. holds cartridge
 - b. chambering specific to cartridge design
 - c. fit of cartridge and chamber critical
3. Muzzle
 - a. where the projectile exits
 - b. points toward impact site
4. Bore
 - a. cylindrical hole between chamber and muzzle
 - b. contains and guides projectile
 - c. diameter specific to caliber
5. Rifling
 - a. spiral ridges (lands) and grooves
 - b. spins projectile for stability
6. Sights
 - a. reference points
 - b. align eye with bore
 - c. align bore with intended point of impact

POINT OUT action of rifles being used or demonstrated. Show each part as it is DISCUSSED.

DEMONSTRATE the open bolt indicator and explain its use as a safety device.

RELATE trigger control to self – control for the shooter. STRESS change from human control to laws of physics – shot cannot be recalled.

DEMONSTRATE operation of safety mechanism on rifles being used. STRESS that safety mechanisms cannot be depended upon – they are only an aid to otherwise safe gun-handling practices.

USE paper towel tube to illustrate rifle barrel.

PASS AROUND section of rifle barrel or use an ILLUSTRATION of one to show various parts and their functions.

STRESS importance of matching ammunition to the chambering. Show barrel stamp, cartridge head stamp and ammunition box information.

STRESS muzzle control again here.

V. Types of rifle sights

- A. "Open" sights
 1. Patridge - sights
 - a. square notch and rectangular post
 - b. more common on pistols
 - c. post centered in notch and even with top of rear site
 2. Notch or vee sights
 - a. V – groove with or without semi-circular notch
 - b. bead or ball on post front sight
 - c. bead centered in notch or base of V-groove
 3. Buckhorn sight
 - a. similar to grooved sight with high, sometimes curved side walls
 - b. bead front sight
- B. Peep or receiver sights
 1. Aperture rear sight
 2. Bead and post, post or aperture front sight
 3. Front sight centered in rear aperture
- C. Optical sights
 1. Aim-points
 - a. superimposed dot on target
 2. Laser sights
 - a. projected dot on target
 3. Telescopic sights
 - a. target viewed through lenses
 - b. may or may not magnify image
 - c. variety of reticles
 - cross-hair
 - post
 - dot
 - duplex (tapered posts and cross-hairs)
 - range finding (multiple stadia wires)
- D. Sight Selection
 1. Selection factors
 - a. rule or regulation restrictions
 - b. visual acuity
 - c. purpose
 - d. expense
 2. Precision shooting
 - a. Receiver sights
 - b. Telescopic sights
 3. Hunting
 - a. Telescopic sights
 - b. receiver sights
 - c. open sights
 4. Plinking, fun shooting
 - a. any sights

POINT OUT sights on rifle being used for this session. ASK participants to DISCUSS functions of sights.

ILLUSTRATE several types of sights using firearms, visual aids or models made from cardboard.

DEMONSTRATE proper sight alignment with each type of sight.

DISCUSS advantages and disadvantages of using each type of sight for various purposes.

NOTE that with practice receiver sights are more easily and more quickly used, as well as being more precise than open sights.

NOTE that aim-points and laser sights are rarely used on rifles today.

If available, ILLUSTRATE variety of telescopic sights and reticle types.

Have participants DISCUSS possible advantages and disadvantages of various types.

LEAD participants in discussing how to select a type of sight for type of shooting that is going to be done.

NOTE that rules of some matches dictate type of sight to be used.

VI. Summary

- A. Review location and range rules
- B. Review fundamental safety rules
 - 1. Muzzle control
 - 2. Action open and empty
 - 3. Finger off trigger
 - 4. Eye and ear protection
 - 5. Personal responsibility
- C. Review the parts and operation of the rifle
 - 1. Stock
 - 2. Action
 - 3. Barrel
- D. Review the types and uses of rifle sights
 - 1. Open sights
 - 2. Receiver sights
 - 3. Optical sights
- E. Review eye dominance and reasons for shooting with the dominant eye
- F. Review Range Procedures

USE discovery teaching technique (questions leading to conclusions you wish to draw) to have participants summarize lesson. BE SURE that all major points are covered.

Lesson Narrative

Instructor note: The first part of the introduction must be customized to the site and any specific rules and regulations that apply to it. Good teaching and learning require that you create a positive, respectful and mutually supportive atmosphere. The range must be firmly and absolutely under the control of the range officer, but the atmosphere must be friendly and supportive. The introductory statement is your first opportunity to set that tone. Exercise great care in phrasing your comments.

As in all other shooting sports lessons, these may be combined into longer sessions if the situation dictates. The greatest concern in longer sessions is fatigue and lapses of attention. Be cautious and aware of young audiences.

Welcome to the first session on rifle shooting. Before we begin today's program, we need to introduce ourselves and become familiar with this facility. Introduce yourself and any other instructors, teen leaders or sponsors. If time permits, have the kids and their parents introduce themselves as well. Note the locations of food and drinks, bathroom facilities and any off-limit areas. Note the time schedule you will be following, too. If an indoor range is being used, stress that no food or drink will be allowed on the range – to avoid ingesting air-borne lead. Shooters must wash their hands and face before eating or drinking any time they handle lead pellets or fire any powder burning rifle.

Rifle shooting is a very safe sport, but it is only as safe as the people participating in it. Because of this, we will be teaching discipline, range control commands and range courtesy as we teach the other elements of rifle shooting. Since each person has only one set of eyes and ears, we will require that everyone on the range wear eye and ear protection during live firing. Tempered eye glasses, safety glasses or shooting glasses may be worn to protect the eyes. Foams plugs, custom fitted plugs or ear muffs may be worn to protect the ears. Shooting safety is mostly common sense and personal responsibility. Those characteristics are usually linked to adult behavior. During these sessions, we will treat you like adults and expect you to act in an adult manner on the range. No abusive, disruptive or foolish behavior will be tolerated. One instance of such behavior will result in the person being removed from the range for that session.

Repeated problems may result in the person being banned from the program. When more than one shooter is shooting on a firing line, some means of control is essential. We will be using a range officer and range commands to control our shooting. All rifles are to be made safe (empty, action open and open bolt indicator inserted) and grounded (placed on the shooting mat) until the range officer gives the command to make ready. Once the make-ready period is completed, the range officer will call "Ready on the firing line? Please respond by firing point number?" Each shooter or coach should respond by stating "ready" or "not ready" and the firing point number. This increases involvement and provides better control of the firing line in the early stages of instruction.



As the shooters become more experienced, this command may be replaced by a more traditional series of commands. "Ready on the right? Ready on the left? Ready on the firing line?" Appropriate pauses follow each one as the range officer watches for responses. Any shooter not ready should raise a hand and call out "not ready." When the range officer has determined that the range is safe and ready, he or she will state "the line is ready." The next command will be "commence firing." In competitions, the range office may state the time limit for shooters to complete that stage of the competition. At the end of the stage or at any time when an unsafe condition develops, the range officer will call "cease fire." At that command the shooters must immediately stop shooting, unload and open their rifles and place them on the bench or shooting mat with the action exposed and the muzzle pointing down range. Anyone may call cease fire if they see an unsafe situation. If the stage is completed, the rifle is made safe and grounded. After doing so, the shooter steps back one step from the firing line and waits for further instruction from the range officer. The purpose of a firing line is to keep all shooters in a line. Should shooters drift back from the line or move beyond it, an unsafe situation might develop. For that reason, everyone on the range should make active shooters stay on the firing line during a shooting session.

There are 10 Commandments of Shooting Safety. For our purposes, we will stick with three cardinal rules.

6. *Always* keep the **muzzle** pointed in a safe direction. That means point it straight up while carrying it into the range area and down range from that point on. It is vitally important to *always* watch where the muzzle is pointed.
7. Keep the **action** open with the open bolt indicator installed until the range officer has declared the range ready and the firearm is loaded for shooting.
8. Keep fingers off the **trigger** until ready to fire.

Following these three simple rules and using a little common sense and courtesy can keep the firing line safe for all shooters.

Eye Dominance

Learning to shoot well is much easier when the shooter uses their dominant eye for sighting. Nearly everyone has a dominant eye, just as they have a dominant hand and a dominant foot. Select a partner and stand squarely facing that partner two to three arm-lengths apart. One member of each pair needs to be an observer. The other member will be the “shooter.” Shooters should extend their arms forward with the hands in front of the waist and place one thumb on top of the other one. Keeping the thumbs in place, cross the fingers of the top hand over the fingers of the bottom hand to form a small triangle. Now, with both eyes open, extend the arms to eye height and look at the observer’s nose through the opening. The observer should note which eye they see looking back through the triangular opening. Then, keeping the nose centered in the opening, the shooter should slowly bring the hands back to his or her face. The opening will come to the dominant eye. The observer should watch for switching between the eyes as the hands move toward the face. The shooter should stand square to the observer without leaning, canting the head or squinting one eye. Try it a couple times to confirm your observation, then switch roles and repeat the process.

How many of you came to your left eye? Right eye? You should shoot with the dominant eye, regardless of whether it is on the same side as your dominant hand. Using the dominant eye reduces tension and eye fatigue and helps in seeing the target clearly and quickly. Keeping both eyes open increases depth perception as well. Those whose eye and hand dominance is on opposite sides are cross-dominant. You should shoot from the dominant eye side, even though it feels clumsy and uncomfortable. Your hands and feet are much easier to train than your eyes. Even if you are already shooting from the “off-eye” side, you will improve more rapidly by switching to the dominant side. A few people are ambidextrous. A similar number are ambi-eyed, that is, their eyes switch dominance when an obstacle is placed in front of them. Shooters with this situation can use a shield, a spot on their shooting glasses or some similar barrier to assure the same eye is used every time they shoot. Even persons with a specific eye dominance may find a barrier device helpful. Be sure you remember which eye is your dominant one so you can use that side in your shooting.

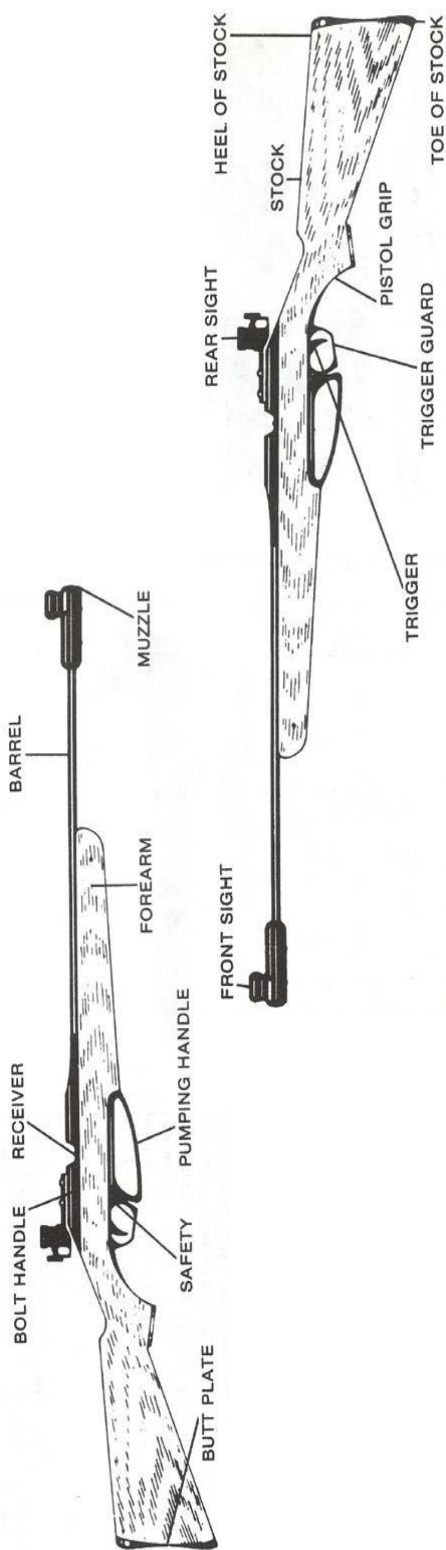

First Shot Fundamentals – Firing the First Shot

The youth who participate in 4-H shooting sports sign up for the project because they want to shoot. The first shot fundamentals concept is designed to allow them to safely fire some introductory rounds so their curiosity can be satisfied and so they will return for the next lessons. The steps in executing the first shot fundamentals can be found on page 6, item III. First Shot Fundamentals. Prior to the session, the range should be set up so the participants will be firing from a bench rest, seated position. Blank sheets of paper should be posted as targets or targets with the backside facing the shooter and the bullseye facing the target frame (target backs). At this stage, we are not concerned with accuracy but simply having them safely fire their first shots. Have the rifles in a rack with open bolt indicators installed. Ammunition must be at a secure point and not on the firing line.

Now that the shooters have determined their dominant eye, provide them with a brief explanation of the rifle parts and rifle sights, and sight alignment (listed below). A detailed explanation of the rifle parts can be provided after firing the first shots.

Safety is the priority. You must have an experienced assistant instructor at each firing point assisting first time shooters and a range master overseeing the operation of the range. Insure all shooters have their eye/ear protection. The range master gives the firing line commands. Give the command “shooters to the line”. Once the shooters are seated, have the assistant instructors bring the rifles to shooters at the bench and demonstrate how the rifles operate while keeping the muzzles pointed downrange. Assistant instructors now allow the shooters to operate the rifles, sight downrange, and dry practice squeezing the trigger.

Once the familiarization period is complete, give the command, “Is the line ready? Respond by firing point number.” If all shooters and assistant instructors are ready, give the command, “The line is ready.” At this time have the assistant instructors pick up five rounds of ammunition from the secure ammunition point and take it to the firing line. Give the command “Make ready.” The assistant instructor may load the rifle. Give the command, “Commence fire.” When shooting is complete, give the commands “Cease fire” and “Make the line safe.” The assistant instructor insures the rifle is empty and inserts the open bolt indicator. The range master confirms that all rifles are made safe and has the assistant instructor return the rifles to the racks.

When all shooters have fired at least five familiarization rounds, they wash their hands to remove all lead particles and return to the class room for more instruction.

Orientation to the Rifle

Rifles, like many other firearms, are composed of three basic elements: a **stock**, an **action** and a **barrel**. These parts work together to make a functioning rifle. The stock functions as a grip or control element and also helps to direct and distribute **recoil** energy. The **forend** or **forearm** is supported by the non- dominant hand (dominance is always related to the eyes). The **forend** provides support for the **barrel** and aids in directing it toward the target. The grip (wrist, small or pistol grip) provides a secure surface for the dominant hand and helps to locate and position the trigger finger.

The remainder of the **butt stock** serves several functions. The comb supports the face and helps to align the eye with the sights. The butt supports the rifle on the shoulder and helps to distribute the recoil energy. In general, the stock helps to position the rifle relative to the shooter and to place its other parts in a location where they can be conveniently used.

The action contains the operating parts of the rifle – those parts that cock, load and fire it. The **bolt** or **breech block** may be involved in cocking the trigger mechanism, but its main function is to lock the cartridge in place and to firmly support its base or head. The **trigger** is a lever that releases the firing mechanism, causing the rifle to fire. In powder-burning rifles, the trigger releases a firing pin or hammer that strikes a primer, setting off the chemical part of the shooting process. In air guns, it releases the air charge to drive the projectile. The **safety mechanism** is another obvious and important part of the action. It is a mechanical device. Like other mechanical devices it can fail or break. The shooter should learn to use the safety only in addition to proper and safe firearm handling. Some safeties block the operation of the trigger. Others may lock the firing pin in place. Still others may lock all parts of the action. However, the only truly adequate

safety is the one behind the bolt – the shooter. Keeping the firearm pointed in a safe direction at all times prevents accidents.

The barrel is a launching tube for the projectile. It is designed to contain the great pressures generated when a rifle is fired. On the action end of the barrel, a specially shaped opening, called the **chamber**, is designed to fit a specific cartridge. It supports the cartridge firmly and allows the case to seal the chamber when the arm is fired. The opposite end is the muzzle. It is the spot where the bullet exits, and it points toward the impact point of the projectile. The cylindrical hole between the chamber and the muzzle is the **bore**. It has a diameter specific to the chambering, which permits the bullet to seal the bore while still being able to pass through it. The rifle bore has spiral set of ridges (lands) and grooves (rifling). These lands and grooves cause the bullet to spin, giving it greater stability in flight.

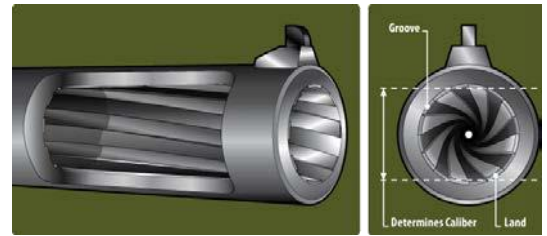

The barrel is fitted with sights. They are reference points that align the eye with the bore so that the shooter looks where the bullet is going. Once the sights are aligned with the barrel, the entire unit may be moved to point the barrel at the intended point of impact. Many different types of sights exist, but all of them serve the same purpose.

Types of Rifle Sights

Rifle sights may be divided into metallic sights and optical sights. Metallic sights can be further divided into **open sights**, those with metal only at the bottom and perhaps sides, and **receiver** or **peep sights**, which use a hole or aperture as an aiming point.



The table below shows which direction the sight knobs must be turned to move to a shot.

	<u>Clockwise</u>	<u>Counter clockwise</u>
Elevation Knob	Up	Down
Windage Knob	Right	Left

Open sights come in a wide variety of designs, but they can be grouped into three basic categories. **Patridge-style sights** have a square notch and flat top on the rear sight and a rectangular post or blade as a front sight. The sights are aligned by centering the post in the rear notch and aligning the top of the post with the top surface of the rear sight. **Notch or V-sights** feature a V-groove with or without a notch in the center. The front sight is usually a bead or ball on a thin post. They are aligned by placing the full ball or bead in the notch or at the base of the V- groove. **Buckhorn sights** are similar to notch sights, but they carry extended “horns” up the sides of the sighting area.

Receiver or peep sights have a relatively small aperture or hole in a disk as a rear sight. The shooter looks through the hole to the front sight, which may be a post, a bead or ball on a post or another aperture. The front sight is simply centered in the opening to align the sights. Receiver sights are more accurate and quicker to use after a little practice than open sights.

Optical sights come in several varieties. Aim-point devices superimpose an electrically generated aiming dot on the target. While they are popular with some pistol shooters, relatively few are used by rifle shooters. **Laser sights** project an aiming dot onto the target. Although they are used by some police and military agencies, the shooting public rarely uses them. Most shooters use a **telescopic sight** when they elect to shoot with an



optical sight. The lenses tend to put the target and the reticle (the aiming device) on a common focal plane, so the shooter can see both of them more clearly. These sights may or may not magnify the target. They eliminate the need for sight alignment and provide more precise aiming than other types of sights. A wide variety of reticles are available in telescopic sights. The most common reticle is a cross-hair or cross-wire design, where the intersection of the stadia wires is the aiming point. Some shooters prefer one or more posts, either flat topped or tapered. Others prefer a dot suspended on extremely fine cross hairs. The duplex style is also popular, where relatively fine tapered posts or coarse tapered cross hairs become a fine set of cross hairs in the center of the scope. Some sights have multiple stadia wires that can be used as a range finder. Each of these reticles has advantages but the duplex, cross hair, dot and post are the most commonly seen.

Sight selection must consider several factors. The rules of the match may restrict the selection. Many matches, for example, stipulate that only metallic sights can be used. The shooter's vision may influence the type of sight that can be used effectively. The purpose for which the sight and the rifle will be used strongly influences the type of sight selected. Expense is also a significant factor. Generally open sights are provided with rifles and are the cheapest. High quality receiver sights and optical sights are much more expensive.

For precision shooting, most shooters rely on either good receiver sights or telescopic sights (when permitted by the rules). Position shooters usually use metallic sights, while light rifle, silhouette or bench-rest shooters usually rely on optical sights. Hunters usually elect telescopic sights or receiver sights, although large numbers of hunters who take their game at close ranges use open sights. Some special hunts, like primitive hunts, require open sights. For **plinking** and fun shooting, any sight that will let you shoot up to your standard of accuracy is fine.

Shooting Journal

Record keeping is an important part of 4-H club work and many of you already maintain a project record book. Shooters also keep records in what is called a shooting journal. Shooters record such things as sight adjustments, target scores, equipment maintenance, etc. You should prepare a notebook that you can use as your journal for this project.

Summary

We have learned about the facilities we will be using and about the basic rules and regulations for using them. We have also learned the three cardinal rules to help keep our shooting safe.

1. We will keep our **muzzles** pointed in a safe direction.
2. We will keep the **action** open and the rifle empty except when actually shooting as directed by the range officer.
3. We will keep our fingers off the **trigger** except when actually firing under the direction of the range officer.

All rules of safe firearms handling apply, but these form the foundation for the target shooter.

We explored the structure of rifles and learned the form and function of the stock, action and barrel. In addition to the parts and functions, we looked at several types of sights and discussed sight selection. We determined our eye dominance and learned why it is important to shoot with the dominant eye. We also discussed some of the ways to ensure that the dominant eye is used in sighting. We fired our first familiarization rounds. Next time we will be using the rifles in a dry-firing exercise on the range.

Summary Activities

1. Have parents or teen leaders go through a range exercise making some deliberate errors in firearms handling. Have participants comment on their mistakes and state what they should have done to handle the firearms properly. Divide into two teams and play an identification game. Show a picture or describe a function of a rifle part. Alternate between teams and make sure each member takes a turn in identifying the parts and/or their functions.
2. Have participants check the eye dominance of their parents or other family members.

Sharing and Exhibit Ideas

1. Diagram and label a rifle and its functional parts in your shooting journal or notebook, or make a poster to illustrate the parts and function of a rifle.
2. Develop a set of posters or signs that reinforce the rules of safe firearms handling on the range.
3. Study a reference on firearms to determine how they work. Study the parts of the firearm more completely. Share your information with other members of your club.
4. Develop a set of firearms safety posters that can be used in teaching the introductory lesson in rifle shooting.

Rifle Action Types

While the 4-H rifle curriculum is written for one type of rifle, specifically the Daisy Model 853, bolt-action air rifle, there are a variety of rifle action types that may be safely used in 4-H shooting sports programs. It is highly likely that, in time, a young shooter will come into contact with a variety of rifle actions. Therefore, a review of the variety of rifle action types and an opportunity for young shooters to be instructed in and practice proper handling and safe operation of the different types of rifles actions is desirable.

Major Rifle Parts

The modern rifle consists of three major assembly groups: **the stock, the barrel, and the action.**

* **Stock** The stock may be made of wood, fiberglass, or other synthetic materials. The stock is designed to provide for the support of the rifle by the shooter's body, and align the axis of the barrel with the dominant eye of the shooter and the intended target in a manner which is comfortable and natural.

* **Barrel** The barrel is a metal tube through which the projectile (bullet) passes when the rifle is fired. The hole through the barrel is called the "bore". A number of spiraling grooves are cut through the bore. These grooves are called "rifling". Rifling causes the bullet to spiral. This spiraling gives the bullet stability in flight and provides for greater accuracy.

* **Action** The action of a rifle contains the functional mechanisms which load and fire the cartridge and eject the empty cartridge case.

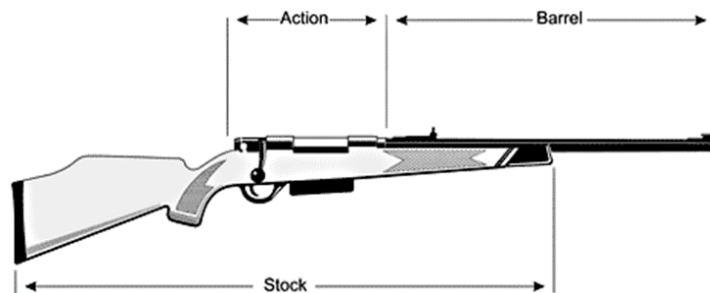

Action Types

Modern rifles may be divided into two groups: repeating and single shot. Single shot rifles require the shooter to load each cartridge manually. These rifles have no supply of ammunition contained within the mechanism of the rifle. Repeating rifles contain a "magazine". The magazine is attached to the rifle and holds a supply of cartridges. Cartridges from the magazine are loaded by the functioning of the action. This functioning may be actuated by the shooter (bolt, lever and slide actions) or by the action mechanism itself (semi-automatic action).

Two common magazine types are tubular magazines and box magazines.

Tubular Magazines: Cylindrical in shape, cartridges are placed 'nose to tail' in a single column and are fed by a spring-loaded device when released into the action mechanism.

Box Magazines: Rectangular in shape, cartridges are 'stacked' into the magazine, either in a single column or staggered. Box magazines can be entirely internal, or removable. Removable ones are commonly called 'clips'.

The Bolt Action:

Bolt action rifles may be single shot or repeating. The operation of a bolt action requires a lift on the bolt handle, a pull to the rear, and a push forward and down. The bolt contains the firing pin and serves as the mechanism to load a cartridge and lock the action. Generally, actuation of the bolt mechanism also cocks the firing mechanism. After a cartridge is fired, this same operation removes and ejects the empty cartridge case.

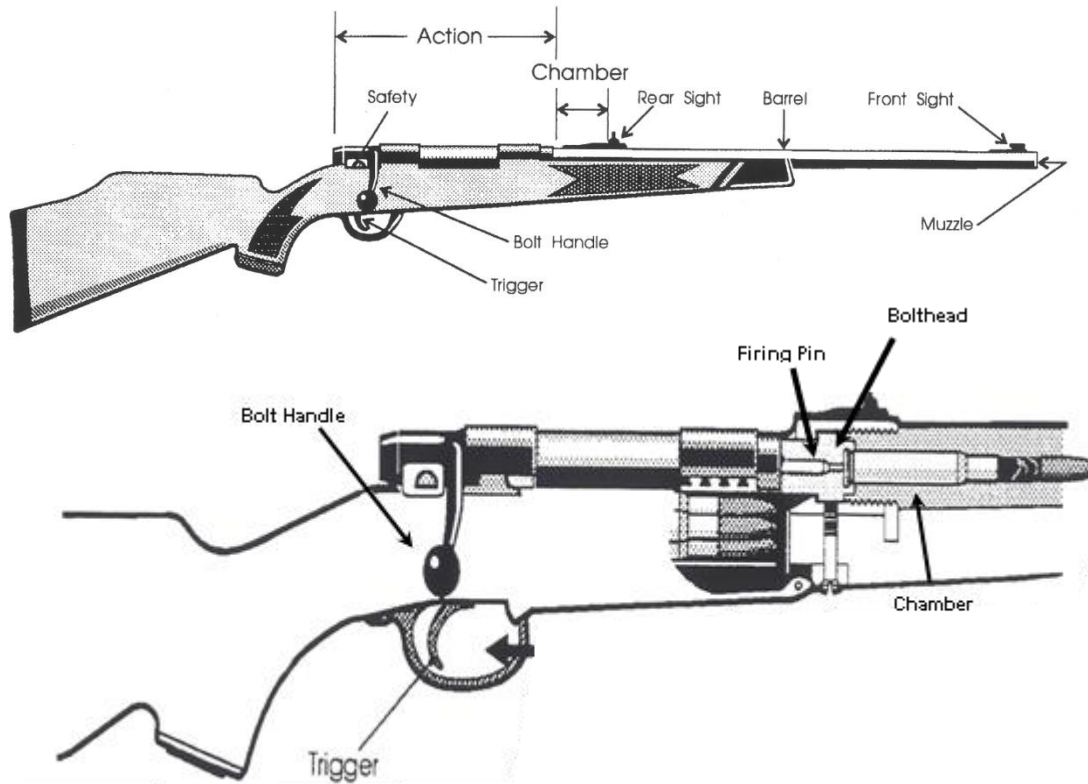

The loading sequence for a bolt action:

1. Open the action by lifting bolt handle up and pulling to the rear
2. Lay cartridge in the open action
3. Push bolt handle forward and down pushing the cartridge into the chamber and locking the action

To unload a bolt action:

1. Open the action, ejecting cartridge from chamber (If the rifle contains a magazine, continue to open and close the action, working each cartridge through it until the magazine is empty)
2. Visually inspect chamber and magazine to be sure the rifle is completely unloaded

The pump or slide action:

The forearm of the stock serves as the actuating device for the action, with the shooter pulling the forearm to the rear toward the action. This serves to open the chamber and extract the spent cartridge. Pushing the forearm forward toward the muzzle loads the rifle. Pump action rifles commonly have a tubular magazine.

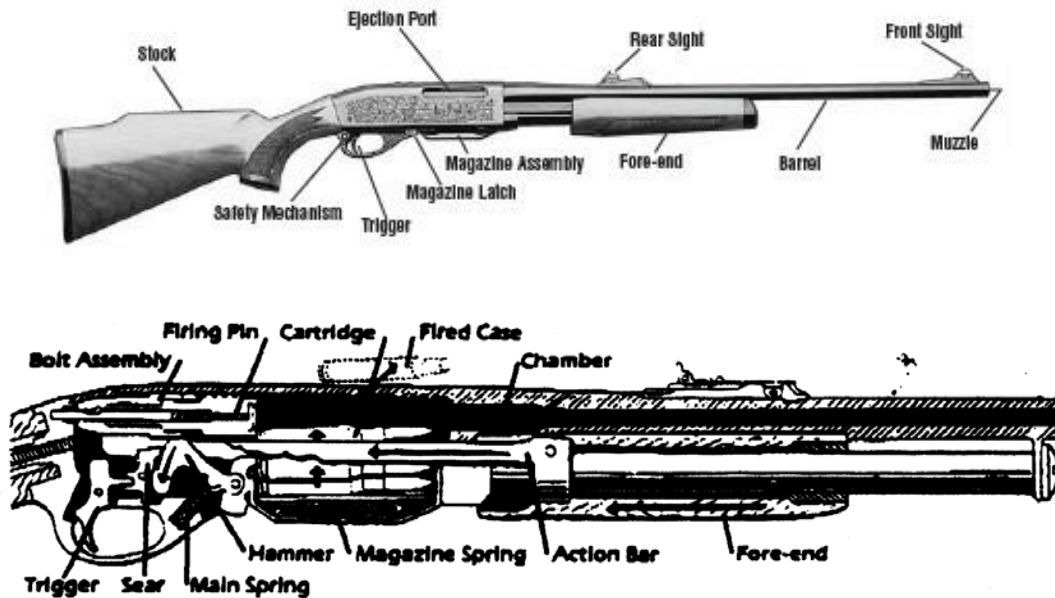

The loading sequence for the pump action:

1. Pull forearm to rear position to open the action
2. Remove magazine plunger tube and insert cartridges into the magazine
3. Replace plunger tube and lock in place
4. Push forearm to forward position

To unload the pump action:

1. Pull forearm to rear position to open the action
2. Open and close action until all cartridges are ejected
3. With the action open, visually inspect chamber and magazine to be sure the rifle is completely unloaded

The Lever Action:

This repeating action rifle is magazine fed, either tubular or box. The cocking lever is located below the action, surrounds the trigger and functions by moving down and forward to unload the chamber or back and up to load the chamber.

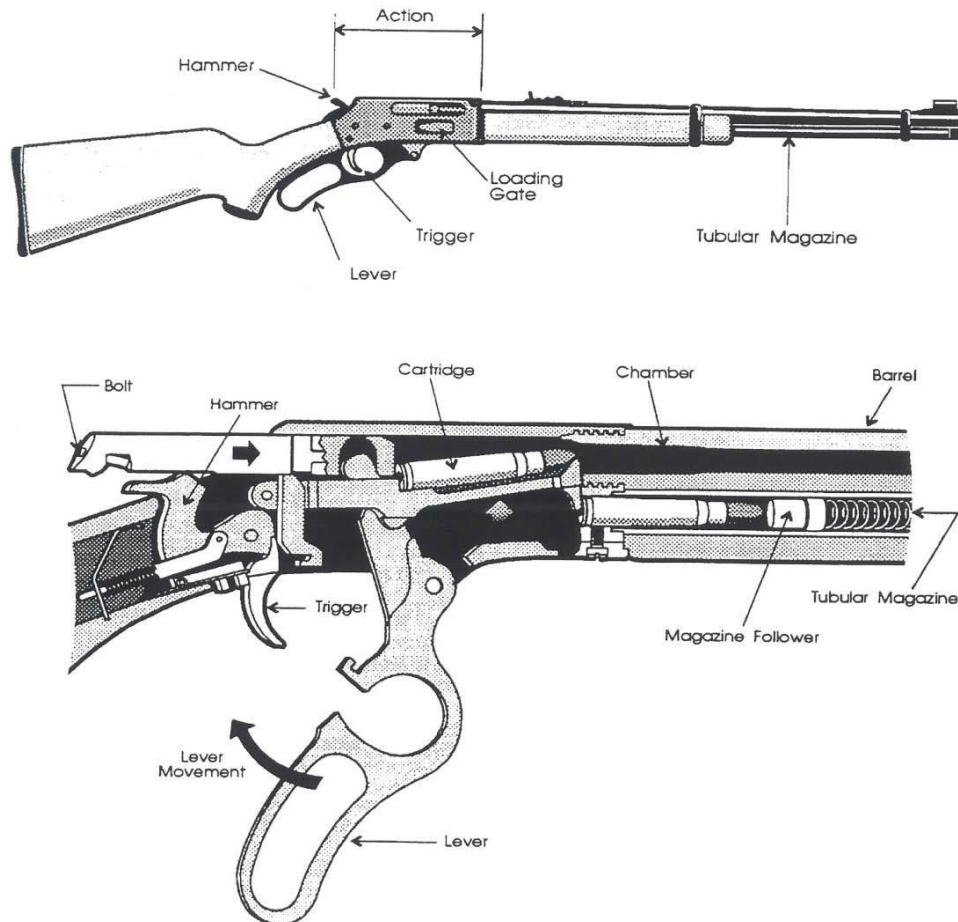

The loading sequence for the lever action is:

1. Insert cartridges into magazine through the loading port
2. Open and close the action to feed a cartridge from the magazine into the chamber

To unload the lever action:

1. Open and close the action until there are no cartridges being ejected
2. With the action open, visually inspect the chamber and magazine to be sure the rifle is completely unloaded

The Falling Block Action:

The falling block action utilizes a breech block instead of a bolt. The action is opened by pushing down and forward on the cocking lever which causes the breech block to “fall” (rotate down) and expose the chamber. Raising the lever closes the action causing the breech block to cover the chamber. All falling block rifles are single shot.



The loading sequence for the falling block is:

1. Lower the lever to open the action
2. Insert cartridge into chamber
3. Raise the lever to close the action

To unload the falling block:

1. Open the action
2. Remove cartridge
3. With the action open, visually inspect the chamber to be sure the rifle is completely unloaded.

The Hinge Action:

The hinge action opens by pushing a release lever that allows the barrel to pivot down and expose the chamber. There are also several brands of rifles of this action type that have more than one barrel, the most common being two barrels, arranged either over/under or side by side.

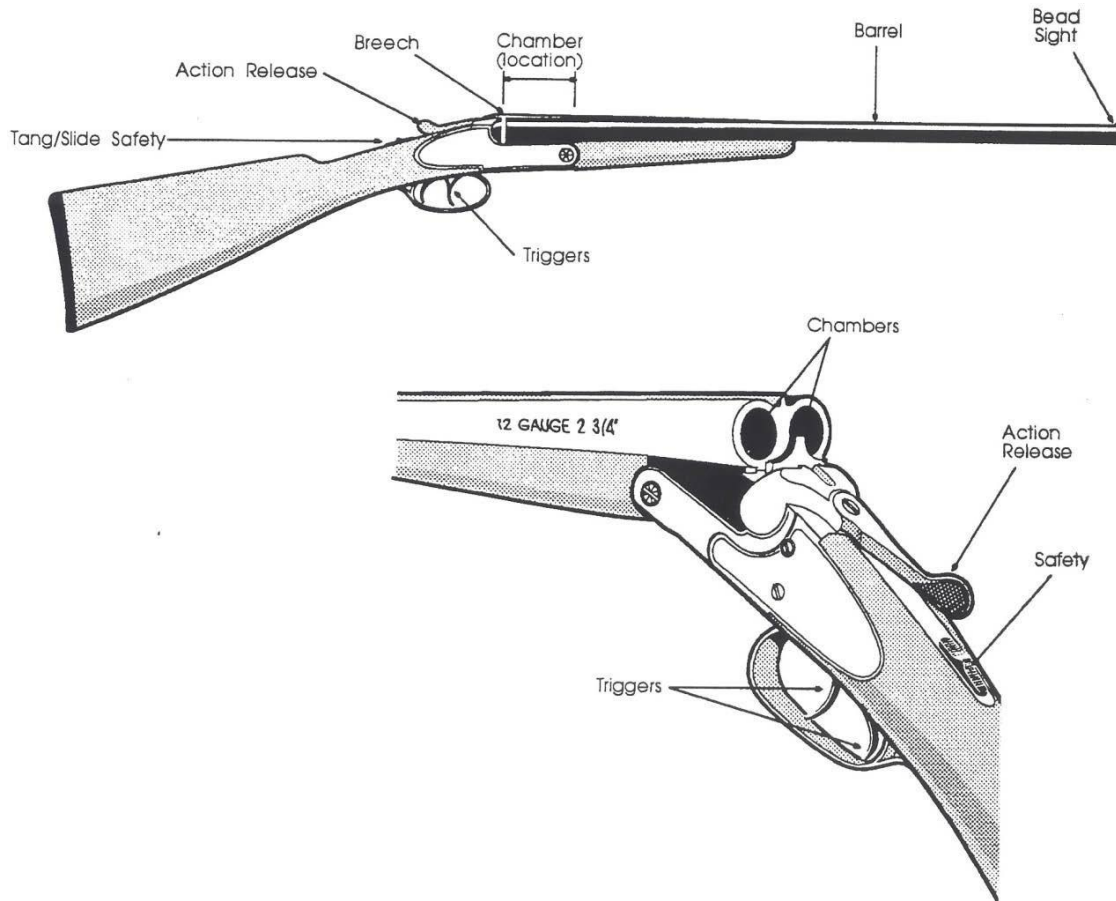

The loading sequence for the hinge action is:

1. Push release mechanism and pivot barrel(s) to open action
2. Insert cartridge(s) into chamber(s)
3. Pivot barrel up into closed, locked position

To unload the hinge action:

1. Push release mechanism and pivot barrel(s) to open action
2. Remove cartridges
3. Visually inspect chamber(s) to be sure rifle is completely unloaded

The Semi-Automatic action:

This repeating rifle action (often called an auto-loader) utilizes the energy generated by the fired cartridge to activate the mechanism to open the action, extract the empty case, load a new cartridge and close the action.

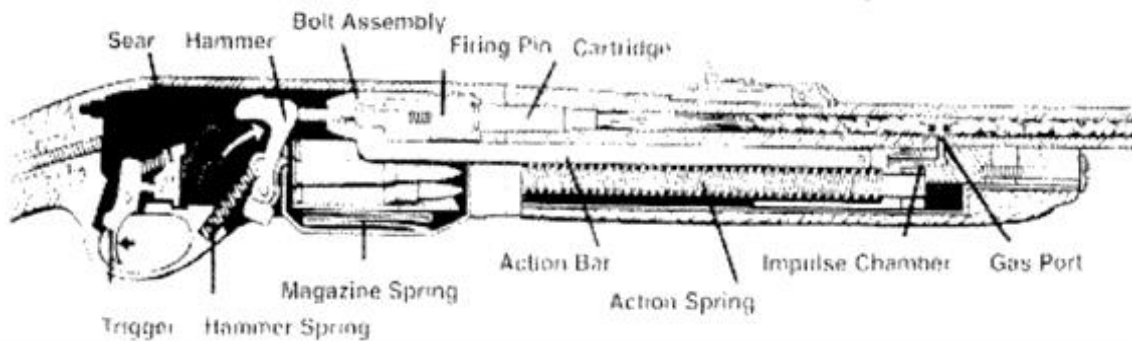
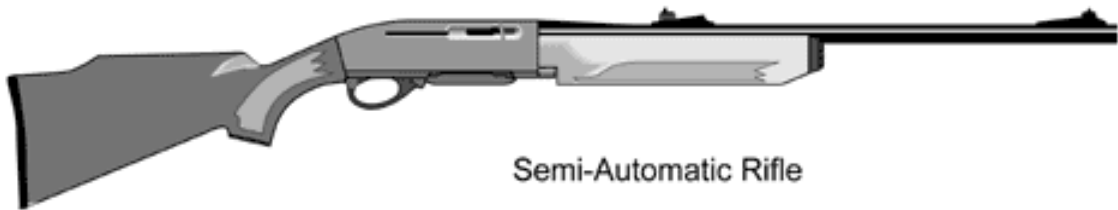

The loading sequence for the semi-automatic is:

1. Pull bolt open and lock
2. Remove and load cartridges into magazine
3. Replace loaded magazine in rifle
4. Close action to load cartridge into chamber

To unload the semi-automatic action:

1. Open the action to eject cartridge from chamber and lock action open
2. Remove magazine
3. With the action open, visually inspect the chamber and magazine to be sure the rifle is completely unloaded

Basic Rifle Lesson 2

Dry Firing Rifles on Target Backs

William F. Stevens, Ronald Howard Jr., John Kvasnicka, and Marilyn Bergum*

Objectives

Participating youth and adults will:

- I. Demonstrate understanding of sight alignment.
- II. Understand and demonstrate trigger control.
- III. Practice safe range and shooting procedures.
- IV. Demonstrate the sequence of elements required to fire a shot by dry firing at target backs from a supported position.
- V. Practice the coach-pupil method of instruction.
- VI. Have fun while learning.

Roles for Teen and Junior Leaders

- Review rifle orientation.
- Demonstrate proper shooting form.
- Demonstrate range procedures and commands.
- Assist “coaches” in helping shooters with problems.
- Tutor shooters with particular difficulties.
- Act as range officers or assistants.
- Assist with trigger control exercise.

Parental Involvement

See Roles for Teen and Junior Leaders above.

- Control one or two shooting stations, assisting range officers and instructors.
- Arrange for or provide transportation.
- Arrange for or provide refreshments.
- Assist with developing exhibits or filling out shooting journal entries.

Best Time to Teach

Any time of year, but prior to shooting at any scoring target.

Best Location

Any safe shooting range

Time Required

About 1 hour (repeat as necessary)

Materials/Equipment

- rifles
- eye and ear protection
- adequate backstop
- blank paper or targets
- shooting bench with pad
- chairs or bench for shooters
- tape or other target mounting materials
- pen, pencil or fine felt tip pen
- eye or medicine droppers
- open bolt indicators

References

NRA Junior Rifle, G. Anderson, National Rifle Association. Washington, DC. 1983
NRA Junior Rifle Handbook, G. Anderson, National Rifle Association. Washington, DC. 1983
The Basics of Rifle Shooting, H. W. Sheets. National Rifle Association, Washington, DC. 1987
Four-in-One Shooting Instruction DVD Basic Rifle Shooting – A Better Way. Contact your state Coordinator or Federal Cartridge Co., Anoka, MN.

*Conservation Affairs Manager, Federal Cartridge Company, Anoka, MN; 4-H and Youth Development Specialist. Texas Agricultural Extension Service; Executive Director. Minnesota Deer Hunters Association; National Rifle Association Field Representative – Minnesota. North Dakota and South Dakota

REVISED by Larry Sullivan and Dick Fultz, 4196

Teaching Outline

Presentation

I. Review orientation to the rifle

- A. Facility and rules
- B. Three basic safety rules
- C. Rifle parts and function
- D. Eye dominance
- E. Sight and sight function

II. Sight alignment

- A. Sights as reference points
 1. Aligning the eye with the bore
 2. Aligning the bore with the intended point of impact
- B. Achieving sight alignment
 1. Focus on front sight
 2. Aligning rear sight with front sight
 3. Maintain front sight focus
- C. Alignment with different sights
 1. Telescopic sights
 1. optics aligned internally
 2. target and sight on same focal plane
 2. Receiver (peep) sights
 1. front sight centered in aperture
 2. "automatic" centering by the eye
 3. Open sights
 1. front sights centered in notch or V-groove
 2. bead centered in groove or blade top even with top of rear sight
- D. Sight alignment critical to accuracy and proper sight adjustment

III. Trigger control

- A. Pressing trigger without changing sight alignment
- B. Pressure straight back on trigger with trigger finger
 1. Pressure on the pad of the trigger finger only
 2. Adjust finger position to apply pressure straight back
 3. Sight alignment remains constant

Application

ASK participants what was covered in last session. Use their responses to **REVIEW** that content. **STRESS** safety and responsibility.

USE sight blocks or cut-outs to show proper alignment of each type of sight.

Move "bead" within aperture to **DEMONSTRATE** centering action of eye.

ASK why consistent sight alignment is important to accuracy. **DISCUSS** answers.

DEMONSTRATE trigger control using an eye dropper. **NOTE** that sights seem to move when whole hand is squeezed. Have an assistant

DEMONSTRATE effects of moving finger on trigger.

IV. Introduction to shooting range commands and procedures

- A. Basic range procedures
 - 1. Range officer in charge at all times
 - 2. Safety first
 - 1. personal responsibility
 - 2. eye and ear protection required of everyone on the range when using firearms
 - 3. No nonsense on range
 - 4. No disruptive or abusive behavior
 - on the range
 - near the range
 - 3. Any special circumstances
- B. Basic rifle safety on the range
 - 1. Muzzle pointed down range
 - 2. Action open and empty except when instructed to load or actively firing
 - 1. exposed for inspection
 - 2. closed means ready to fire
 - 3. Finger off trigger except when firing
 - 4. Procedure if problem occurs
 - 1. cease fire if necessary
 - 2. keep rifle pointed down range
 - 3. raise hand for help
- C. Range commands
 - 1. "Shooters to the line"
 - 2. "Is the line ready? Respond by firing point number"
 - 3. "The line is ready"
 - 4. "Pick up your rifles" (or make ready)
 - 5. "Commence firing"
 - 6. "Cease fire"
 - 1. immediate response each shooter's right & responsibility
 - 2. end of stage or unsafe condition
 - 7. "Make the line safe"
 - 1. safety on
 - 2. open action and insert open bolt indicator
 - 3. remove all ammunition
 - 4. place rifle on mat or bench
 - 5. muzzle down range
 - 6. action open, empty, exposed to view

EXPLAIN basic range rules and **DISCUSS** reasons for them.

STRESS importance of personal responsibility, protecting sight and hearing and orderly behavior. **DISCUSS** how disruption can cause dangerous reactions.

REVIEW responses to improper behavior

COVER any special rules or safety considerations

REVIEW and DEMONSTRATE basic rifle handling on range.

DEMONSTRATE how to handle a problem, like a hang-fire

DEMONSTRATE and DISCUSS range commands and proper responses by shooters. Refer to *Fact Sheet 16: Rifle and Pistol Range Commands and Procedures* for more detail and explanation.

USE clear and consistent range commands while shooters are learning to ensure safety and reinforce shooting procedures

V. Basics of rifle operation

- A. Picking up your rifle
 - 1. Muzzle down range
 - 1. shooter responsibility
 - 2. coach reinforcement
 - 2. Safety on
 - 1. location and operation
 - 2. explain "safe" or "on"
 - 3. explain "fire" or "off"
 - 3. Empty with action open
 - 1. closed action means ready to fire
 - 2. open action visible
 - 4. Finger off trigger
- B. Loading and unloading
 - 1. Process
 - 1. placing projectile in chamber
 - 2. close and lock action
 - 3. reverse process to unload
 - 2. Control of ammunition
 - 1. identify correct calibers
 - 2. control all live ammunition
 - 3. control distribution of ammunition
 - 3. Charging air rifles
 - 1. Operation
 - 2. safety - avoiding pinches
 - 4. Use of dummy ammunition
- C. Assume shooting position
 - 1. Stance or position
 - 2. Refer to specific lesson for details of position
- D. Safety off
- E. Align sights
- F. Fire when ready
 - 1. Trigger control
 - 2. Follow through
- G. Cease fire

VI. Coach-pupil method of instruction

- A. Pairs of shooters learning together
 - 1. Reinforcing proper technique
 - 2. Learning by doing
 - 3. Backed up by range staff
- B. Roles of coach
 - 1. Watch all safety procedures
 - 2. Watch muzzle control
 - 3. Assist with rifle placement
 - 4. Control ammunition
 - 1. load rifle in beginning
 - 2. assist with loading later
- C. Adult or teen staff at each firing point as back-up

DEMONSTRATION each part of this with rifles being used for instruction

MATCH shooters in coach-pupil pairs. Having same eye dominance helps with some learning situations.

ASSIGN adult assistants or teen leaders to every firing point.

VII. Dry firing

- A. Going through the shooting sequence without ammunition
- B. Reasons for dry firing
 - 1. Avoid tension and noise of live firing
 - 1. greater concentration on learning how to shoot
 - 2. develop feel for trigger
 - 3. develop smoothness
 - 4. experiment with finger placement
 - 5. develop consistent trigger control
 - 6. develop consistent sight alignment
 - 2. Use dummy ammunition

VIII. Dry firing at target backs

- A. Reasons for using blank targets
 - 1. Less distraction
 - 2. Concentration on sight alignment
 - 3. Concentration on trigger control
- B. Coaches" and range assistants watch form and safety
 - 1. Muzzle control
 - 2. Focus on front sight
 - 3. Trigger control
 - 4. Follow through

IX. Bench-rest position

- A. Shooter seated, square to target
- B. Rifle supported at forearm
 - 1. Sandbags
 - 2. Cradle
 - 3. Commercial rifle rest
- C. Rifle butt in shoulder pocket
- D. Elbows resting on bench
- E. Dominant-side hand on grip
 - 1. Finger along trigger guard
 - 2. Finger OFF trigger
- F. Non-dominant hand
 - 1. Flat on bench
 - 2. Bracing sandbag under the grip
 - 3. Bracing dominant elbow
- G. Cheek resting on comb with eye in line with sights
- H. Adjust position by moving rest or sandbags

BE SURE all shooters completely understand. **DO NOT ASSUME** they know either process or language being used. **STRESS** each vital point.

MATCH shooters in coach-pupil pairs. Having same eye dominance helps with some learning situations.

ASSIGN adult assistants or teen leaders to every firing point.

BE SURE NO LIVE AMMUNITION is present.

DISCUSS purpose in using the blank side of the target. **REINFORCE** idea that we are working on **FUNDAMENTALS**: position, sight alignment, and trigger control.

MAINTAIN constant and immediate control over each firing point.

DEMONSTRATE bench-rest position and have all participants **PRACTICE** using it without rifle.

STRESS importance of moving supports and rifle to target rather than trying to "muscle" it into place.

Have each shooter **FIRE** their first dry-fired shot following step- by-step commands of instructor. Note that using bench position minimizes fatigue. If greater concentration on trigger control is needed, **USE** telescopic sights if available.

X. Dry firing from a bench-rest position

- A. Maintain a bench-rest position
- B. Dry fire by command
 - 1. Use clear and consistent range commands
 - 2. Shooting procedure as above
 - 3. Repeat for several "shots"
- C. Reverse roles and repeat sequence

XI. Summary

- A. Sight alignment
 - 1. Front sight focus
 - 2. Front sight centered in rear sight
 - 3. Appropriate to sight type
- B. Trigger control
 - 1. Fire without disturbing sight alignment
 - 2. Follow through
- C. Range commands and procedures
- D. Shooting procedure
- E. Bench-rest position
- F. Dry firing practice
- G. Live firing begins in the next session

ASSIST shooters having difficulties, but **AVOID** over-coaching and excessive shooting. Excessive shooting, even dry firing, or too many things to consider only slow learning. Space needed between these sentences.

USE questioning process to let shooters **REVIEW** lesson.

STRESS main points in safety and technique. **SUPPLY** any significant points they may miss.

NOTE that live firing will begin with the next session on range.

Lesson Narrative

In the last session, we discussed the facilities and the basic rules for using them. We reviewed the basic rules for shooting safety on the range and emphasized three of them: **muzzle** pointed in a safe direction, **actions** open and empty and finger off the **trigger**. We noted that both eye and ear protection are essential for all persons on the range. Some situations with air rifles may require ear protection, but not all. We discussed the parts of the rifle and how they work. We checked our eye dominance, and we discussed sights and how they operate. In this session, we will be dry firing to practice sight alignment and trigger control.

Sight Alignment

Sights are reference points that aid in aligning the shooter's eye to the bore of the rifle. Once the bore and the eye are aligned, the bore can be pointed at a desired point of impact. With **metallic sights**, the shooter focuses on the front sight. The front sight is then positioned properly in the rear sight, keeping the front sight in sharp focus and allowing both the rear sight and the target to be slightly blurry.

Sight alignment differs with the various types of sights. With **telescopic sights** (scopes), the lenses inside the sight align the sighting device or reticle with the bore. The target and the **reticle** appear on the same focal plane, so both of them are in sharp focus at the same time. Adjusting the sight setting changes the relationship with the bore, but on most modern scope sights, the reticle remains centered. **Receiver** or **peep sights** are aligned almost automatically by the eye. As the front sight is viewed through the rear aperture, the eye tends to center the front bead or post in the aperture. When a front aperture is used, the eye tends to center the inner aperture in the outer (rear) one. Concentration on the front sight is somewhat automatic, since the rear sight is too close to the eye to remain in focus.

Open sights are properly aligned when the front sight is centered in the notch or V-groove. Partridge-style sights center the front blade in the notch and level the top of the blade with the top of the rear sight. Other styles center the bead in the notch or groove in the rear sight. More concentration may be required to focus on the front sight with the multiple images of an open sight and a target.

No matter what type of sight is used, proper sight alignment is critical to accurate shooting. Improperly aligned sights will not even allow the shooter to adjust sights to the barrel adequately. Practicing sight alignment can lead to improved shooting and tighter groups.

Trigger Control

Trigger control simply means learning to press the trigger directly to the rear in a smooth motion with constant pressure and without disturbing the sight alignment or sight picture. While many shooters suggest squeezing the trigger, that idea sometimes prompts shooters to apply pressure with the entire hand. Such pressure almost invariably disturbs the sight alignment. Proper trigger control requires that the only change in hand pressure be the straight-back push of the trigger finger on the trigger. Adjusting the trigger finger placement on the trigger can aid in achieving a straight-back pressure. Pistol shooting demands good trigger control and is excellent practice for good rifle shooting.

Proper trigger control can be demonstrated and practiced with an exercise using an eye dropper. With the eye dropper filled and held between the thumb and the tip of the index (trigger) finger, press gently with the finger to drop several drops, one at a time, on the same "target." Then try by squeezing with the whole hand or moving both the thumb and the finger at the same time. You will see that the first method is

more precise. Try holding the entire hand still while moving only the trigger finger. As you overcome the tendency to move the entire hand, your ability to maintain sight alignment will increase.

Range Commands and Procedures

The first rule of range etiquette and safety is that the range officer is in complete and absolute control of the range at all times. Safety is our constant and primary concern, and the range officer's first priority is to maintain range safety. Everyone on or near the range is personally responsible for safety as well. To protect sight and hearing, eye and ear protection is required of all persons on or near the range. In addition, no nonsense, disruptive activity or abusive behavior will be permitted on or near the range. Shooters, particularly beginning shooters, need to concentrate on safety and the fundamentals of proper shooting. Distractions reduce concentration, hinder learning and create potentially dangerous situations. They cannot and will not be permitted. Participants who fail to exercise good judgment and the highest standards of behavior will be removed from the shooting range for the duration of that session. Repeated problems may result in being banned from the entire instruction program.

Three simple and basic rules apply to firearms handling to help keep the operation of the shooting range accident free. First, **muzzles** will always be kept pointed in a safe direction. They should be held straight up when the rifle is being brought into the range and pointed down-range at all times when it is on the firing line. The shooter (and coach) must watch muzzle direction at all times. Second, the rifle will be kept empty with the **action** open and exposed to view at all times except when it is actually being fired. Range officers or their assistants will inspect every rifle when it is brought onto the range or removed from it. The action should be open at that time for their inspection. Third, the finger will remain off the **trigger** except when the shooter is in the act of firing, either dry firing or with live ammunition.

If a problem arises while shooters are on the range, a shooter must decide what to do. If any unsafe condition is present down range, the shooter should call "cease fire" immediately. If a malfunction or equipment problem occurs a shooter should raise his or her hand to signal the range officer or an assistant. The rifle must remain pointed down-range at all times. Keeping the rifle pointed down range is particularly important if an ammunition malfunction or misfire occurs. The rifle should remain pointed down range for at least three minutes before the action is opened. Faulty ammunition should be placed in the barrels provided for proper disposal. We will use range commands consistently, and shooters and coaches are expected to learn them. The following are basic commands, you may add to these as the situation dictates, e.g., large groups of shooters, matches, etc. or use the Expanded Range Commands (below) when working with novices, but always use these Basic Range Commands as a minimum standard.

BASIC RANGE COMMANDS

"Shooters to the line" instructs shooters to move to the firing line. *"Load"* allows shooters to handle their rifles and load them. *"Commence firing"* signifies that live firing may begin.

"Cease firing" signifies that all firing stops and rifles must be unloaded or it signifies an unsafe situation where all firing stops and rifle actions are opened.

EXPANDED RANGE COMMANDS

"Shooters (or relay [number] to the line" instructs shooters (or coach-pupil pairs) to move to the line with their equipment. All equipment should be made safe, inspected and grounded at the shooting line. The muzzle must be pointed down range and the action must be open and exposed to view.

"Is the line ready? Please respond by firing point number. "This query demands a response, either positive or negative, from every shooter or coach. After shooters gain more experience and confidence with range procedures, we will switch to a more conventional response. Then only shooters who are not ready will reply. Many shooters signify their readiness with a wave of the hand. Anyone who is not ready at this point should respond with a "not ready."

Once the range officer is satisfied that the line is ready, he or she will declare *"the line is ready"*. *"You may handle your firearms,"* or *"The preparation period begins now"* allows shooters to handle their rifles. The rifles may be picked up and adjusted to the shooter at this command, but they MAY NOT be loaded. Preparing to load the rifle comes after the range officer declares the preparation period at an end. The range officer will state the readiness of the range, then declare it open by stating, *"Ready on the right. Ready on the left. Ready on the firing line"* This is the final opportunity to indicate that more time is needed.

Mechanical safeties are seldom used by serious target shooters, since the rifle is loaded only in preparation to being fired. To reinforce use of the safety and to add another safety checkpoint to our shooting procedure, we will keep the safety on except when the rifle is ready to fire. The range officer will issue the command *"Safeties off"* to move the safety to the fire position.

"Commence firing" signifies that live firing may begin. The rifle may now be loaded and fired. In competitions, the range officer will usually state the time allowed for the stage just prior to declaring the range open to live firing. Initially, the range officer will issue a series of commands to control actions on the range further. *"Load"* means the rifle may be loaded and charged if necessary. *"Align the sights,"* means to obtain a proper sight picture. *"Obtain a sight picture"* means to hold the sights on the target. *"Press the trigger,"* means to fire a controlled shot at the target. *"Follow through,"* means to hold the sight alignment and sight picture through the shot. These extra commands will be eliminated after the shooters are familiar with the firing sequence.

"Cease fire. may signify either the end of a time period for a stage or the presence of an unsafe condition. It means that all shooting is to stop *immediately*. Even a shot that is just about to "break" should be held back if it is possible to do so. At that command, all shooters and coaches repeat the command out loud, all shooting stops, the action is opened, and any live ammunition is removed from the firearm. *"Make your rifles safe"* requires you to double-check the rifle to be sure that it is empty and the action is open. Insert the open bolt indicator. Some range officers will then tell you to *"Ground your rifles.* This means place them on the shooting mat pointing down range with the action open and exposed to view. Just as rifles are the first part of the equipment carried onto the range and checked as they enter, they are removed from the range first at the end of a relay. Rifles should be ready for inspection as they are being taken from the range, just as they were when being carried onto the range.

Rifle Operation

We learned the basic parts of a rifle and how they work in the last session. Each shooter should be completely familiar with the operation of his or her rifle. Study the owner's manual carefully or have someone who understands the rifle demonstrate its features for you.

Please pay close attention to the teen leaders as they demonstrate some basics of rifle operations. The safety is located on the trigger guard, or behind the bolt handle on the receiver, or on the rear of the bolt, or on the receiver tang. Most safeties located on the tang or the receiver are pushed forward to the fire position. Those mounted on the rear of the bolt are usually rotated to the right to fire. Cross-bolt safeties, found on the trigger guard, come in both right-handed and left-handed versions. They are pushed away from the dominant hand to fire. Study the safety on your rifle, and examine how it operates with the assistance of a teen leader or assistant. The basics of loading and unloading are also extremely important. We will be single loading our projectiles. Each pellet or cartridge is placed in the rear of the chamber and locked into place by moving the bolt forward. In many bolt-action rifles, the bolt is also rotated after it is closed to lock it in place. Practice the procedure without using any ammunition. In the beginning, the "coach" in each coach-pupil pair will be controlling all ammunition.

Muzzle control is critical in all phases of using a firearm. The shooter is responsible to watch where the muzzle is pointing at all times. "Coaches" should reinforce proper muzzle control, stopping the movement of the rifle if necessary. Range staff will watch each firing point in the beginning to support both the coach and the shooter. Air rifles have an additional safety concern. They must be charged with air before they can be fired. The rifles we are using require a single air charge. The operating handle is moved fully forward, then is pulled back and locked in place. Be sure to keep the muzzle pointed in a safe direction throughout the process. Also, keep your fingers clear of the charging lever while it is being moved. On many airguns the charging lever closes by snapping sharply into place. They can give you a nasty pinch if you are not careful.

Coach-pupil Instruction

The coach-pupil method involves pairs of shooters who change roles during the course of instruction. The "coach" reinforces proper technique, learns by instructing and supports the shooter. Coaches watch for compliance with all safety measures. They observe muzzle control and intervene if the muzzle strays from a down-range orientation. Coaches assist the shooter in getting the rifle properly placed on the bench or the shoulder. They control the ammunition and load the rifle in the beginning stages of learning. They also move the safety to the "fire" or "off" position and announce the condition to the shooters. Later, they may assist the shooter with loading. An adult or teen assistant will be available to support each coach-pupil pair.

Dry Firing

Dry firing is a valuable and inexpensive way to practice rifle shooting form. It is simply going through all the motions of shooting without ammunition. The shooter is free from worrying about scores and the noise of live firing, allowing greater concentration on the fundamentals of shooting. Dry firing helps to develop a feel for the trigger. No noise or recoil will disturb the process of developing a smooth trigger squeeze. Faulty trigger control can be detected because the movement is not covered by recoil. The shooter can experiment with finger placement on the trigger to achieve a straight-back pressure. Dry firing also helps the shooter develop consistent form, sight alignment, sight picture and follow through.

Air rifles may be dry fired merely by shooting without loading a pellet. Most air pneumatic air rifles may be dry fired without causing damage to the rifle. Since dry firing can severely damage spring-piston air rifles, always check with a competent authority to determine if the rifle you are using may be dry fired without damaging it. Rimfire and center-fire rifles may use snap caps or dummy rounds to cushion the firing pin.

Dry Firing at Target Backs

Initial dry firing and live firing will involve target backs rather than regular targets. Shooting at target backs emphasizes shooting groups and shooting form rather than hit location or scores. Thus, the blank target is a better learning environment for the shooter. The shooter should concentrate on proper and consistent sight alignment and good trigger control. Coaches should watch muzzle control and other safety elements. They should also help shooters concentrate on focusing on the front sight, trigger control and following through the shot.

All shooters should start from a supported, bench-rest position. The shooter is seated squarely to the target behind the bench. The rifle is supported under both the forend and the grip by sandbags, a cradle, a commercial rifle rest or similar supporting materials. The shooter's elbows rest on the bench. The dominant-side hand (shooting hand) holds the grip of the rifle, with the finger along the trigger guard. The "off" hand lies on the bench, braces the elbow of the shooting hand or braces the sandbag under the grip. The cheek rests on the comb with the dominant eye in line with the sights. The sights are moved to the desired point of impact by moving the rest and the rifle, not by muscling the rifle into position. The rifle should be stable. For the duration of the dry-firing exercise, the rifles should be empty or loaded with inert ammunition. No live ammunition should be present.

The first "shot" for each shooter will be fired on command. With the first relay on the line, have the shooter get into a good bench-rest position with the aid of the coach. After a few moments, determine the shooters' status by asking *"Is the line ready? Respond by firing point number, please"*. Each shooter or coach should reply by stating the number of their firing point and either "ready" or "not ready" Query any non-responders directly by number or name. . Once they are in position and settled (adults or teen assistants may need to help here), have the shooters insure their safeties are on and have the coaches remove the open bolt indicators." On the command *"coaches, cock your rifles"* coaches should cock their rifles and charge them with air if necessary. The coach switches the safety to *"fire"* on the command *"safeties off"* Shooters should get into position again and *"align the sights"* Caution shooters to align the sights properly and carefully. The *"center the sights on the target back"* command may require adjusting the rifle or rest positioning. *"Keep the front sight in focus, or press the trigger and follow through"* should result in a ragged series of reports or clicks. Next, issue the command *"safeties on."* Coaches should verify the safety position.

Then command *"make your rifles safe"* Shooters should open the action, insert the open bolt indicator leaving the muzzle pointed down range and the rifle supported in the bench-rest position. This sequence should be repeated several times before the shooter and coach switch roles. Repeat the dry firing exercise several times with each shooter. Watch for lack of attention, signs of boredom or confusion.

Summary

Proper sight alignment involves focusing the eyes on the front sight and centering it in the rear aperture, or in another pattern appropriate to the type of sight. Aperture and telescopic sights are preferred for this stage of instruction. Proper trigger control involves pressing the trigger until it "breaks," releasing the sear or firing the rifle without disturbing the sight alignment. That undisturbed sight alignment should be maintained during and after the firing with a solid follow through for the shot. We applied these principles by dry firing at target backs from a bench-rest position.

In addition to these mechanics, we have learned and practiced safe range management and operation procedures. Those procedures and commands have been practiced in a dry firing context. You have learned that dry firing is an excellent way to practice the fundamentals of shooting.

Remember that we will be shooting live ammunition in our next session. No one will be allowed to shoot without proper eye and ear protection, so be sure to bring it with you to the meeting.

Summary Activities

1. Have participants discuss the main points of the session (self- control, sight alignment and trigger control) and the reasons that they are important to good shooting.
2. Have participants record what they learned about sight alignment, trigger control and range operations in their shooting journal or notebook.
3. Have a more experienced shooter discuss why these basic elements of shooting are important to them and how they practice them. Emphasize mental control and dry firing.

Sharing and Exhibit Ideas

1. Exhibit your shooting journal or notebook, showing the learning steps you have recorded during this series of lessons.
2. Develop a demonstration of a sight alignment exercise, and explain why sight alignment is important to good shooting.
3. Make a set of safety posters or signs for the ready area at the entrance of the shooting range, reminding shooters of their responsibilities on the range.
4. Build a shooting bench.
5. Make a set of sandbags to be used in bench-rest shooting.
6. Discuss shooting safety and proper shooting form with one or more friends.

Shooting for Groups on Target Backs

Ronald A. Howard Jr., William F. Stevens and John Kvasnicka*

Objectives

Participating youth and adults will:

1. Demonstrate sound rifle shooting principles using live ammunition.
2. Effectively shoot groups using a center-of-mass hold on a blank target.
3. Practice safe range and shooting procedures.
4. Have fun while learning.

Roles for Teen and Junior Leaders

- Review rifle orientation.
- Demonstrate proper rifle shooting form.
- Demonstrate range procedures and commands.
- Assist coaches in helping shooters with problems.
- Tutor shooters with particular difficulties.
- Act as range officers and assistants.
- Assist with trigger control exercise.

Parental Involvement

- See Roles for Teen and Junior Leaders above –
- Coordinate or provide transportation to the range.
- Coordinate or provide refreshments after the session.
- Assist instructors with control of each firing point
- Act as assistant range officers or range officers.
- Assist youngsters with particular difficulties by providing personal attention to their needs.

Best Time to Teach

Any time of year, but prior to shooting at any scoring target

Best Location

Any safe shooting range

Time Required

Approximately 1 hour
(Repeat as many times as necessary)

Materials/Equipment

- rifles
- appropriate ammunition
- adequate backstop
- blank paper or rifle targets
- eye and ear protection
- shooting bench with pad
- bench or chair for each shooter
- sandbags or other riflerests
- tape or other target mounting materials
- pen, pencil or fine felt-pen
- eye droppers
- open bolt indicators

References

NRA Junior Rifle Shooting. G. Anderson. National Rifle Association, Washington, DC. 1983.
The NRA Junior Rifle Handbook. G. Anderson, National Rifle Association, Washington, DC. 1983.
The Basics of Rifle Shooting. H.W. Sheets. National Rifle Association, Washington, DC. 1987.
Four-in-One Shooting Instruction DVD Basic Rifle Shooting - A Better Way. Contact your state coordinator or Federal Cartridge Co., Anoka, MN.

*4-H and Youth Development Specialist, Texas Agricultural Extension Service; Conservation Affairs Manager for Federal Cartridge Company, Anoka, MN; and Executive Director, Minnesota Deer Hunters Association.

Teaching Outline

Presentation

I. Review

- A. Safety rules
- B. Eye and ear protection
- C. Sight alignment
- D. Trigger control
- E. Loading and unloading procedure
- F. Range commands
- G. Shooting procedures

II. Repeat and review dry firing

- A. Shoot from bench-rest position
 - 1. Rifle supported on sandbags or other rest
 - 2. Shooter seated and supported at bench
 - 3. Blank target
- B. Repeat dry-firing exercise
 - 1. Press or squeeze trigger to reestablish feel
 - 2. Align sights, center on target back and dry fire
 - 3. Repeat several times with each coach-pupil pair

III. Live firing at target backs

- A. Define live firing
 - 1. Actually firing a projectile
 - 2. Point of impact evident
 - 3. Indicates where muzzle was pointed
- B. Ammunition being used
 - 1. Discuss type
 - a rimfire
 - b center-fire
 - c pellet
 - 2. Coaches control ammunition
- C. Shooting for groups
 - 1. Objective is to shoot groups
 - 2. How to shoot groups
 - a proper sight alignment
 - b good trigger control
 - c consistent hold on target center
 - 3. Coaches and assistants watch form and safety
 - a muzzle control
 - b focus on front sight
 - c trigger control

Application

ASK participants to **REVIEW** the elements of safe, controlled and consistent shooting. **STRESS** main points, adding any essential ones to their review.

DRY FIRE to help shooters review process of firing a shot, stressing sight alignment and trigger control.

WATCH constantly for form, safety and fatigue.

Use rifles that will be shot in this session to **DEMONSTRATE** all procedures.

STRESS importance of shooting groups, not group location.

REVIEW these elements once more.

MAINTAIN constant and immediate control over every firing point with adult or experienced teen leader.

- D. Demonstrate proper loading procedures
 - 1. Refer to owner's manual
 - 2. Reinforce safety rules
- E. Discuss live firing procedure
 - 1. Muzzle down range and finger off trigger
 - 2. Safety on
 - 3. Load rifle (charge if needed)
 - a may be done by coach
 - b coach moves safety to "fire"
 - state rifle is ready to fire
 - wait for "thank you" to release control of rifle
 - 4. Align sights
 - a focus on front sight
 - b front sight aligned with rear sight
 - c hold aligned sights on center of target back
 - 5. Squeeze trigger
 - a focus on front sight
 - b maintain sight alignment
 - c hold until projectile hits backstop
 - 6. Make rifle safe
 - a safety on
 - b muzzle down range
 - c action open, open bolt indicator inserted
 - d rifle firmly in bench position

IV. Live firing at target backs

- A. Maintain bench-rest position
 - 1. Coaches reinforce proper position
 - 2. Review position if needed
- B. Live firing on commands
 - 1. Use expanded range commands and shooting procedures
 - 2. Repeat sequence several times
 - 3. Allow shooters to fire several shots on their own
 - 4. Reverse roles and repeat

USE coach-pupil pair made up of teens or parents to **DEMONSTRATE** loading and unloading.

DEMONSTRATE a proper live firing process with a group of adults or teens as it is being explained. Have shooters **OBSERVE** at each firing point.

REINFORCE need for communication and control over rifle.

Coaches or instructors **CONTROL** all live ammunition.

ASSIST any shooter having problems, taking all needed time.

DO NOT over coach or allow shooters to fire too many shots without break. Excessive shooting or too many things to think about slows learning. **AVOID FATIGUE** and **USE** breaks for evaluation and instruction

V. Evaluating Groups

- A. Review shooting for groups
 - 1. Consistency
 - 2. Sight alignment
 - 3. Trigger control
 - 4. Center-of-mass hold
- B. Fire a carefully held, 5-shot group
 - 1. Small groups (nickel to dime size)
 - a Adequate mastery of basics
 - b Ready to move on to target faces
 - c Location not important
 - 2. Large or inconsistent groups
 - a Review basics
 - b Continue using bench-rest position
 - c Keep pressure OFF shooter by staying with target backs
- C. Allow shooters to proceed as they are ready

VI. Summary

- A. Review sight alignment
- B. Review trigger control
- C. Review dry-firing and live- firing procedures
- D. Respond to any questions
- E. Encourage use of shooting journal

ASK what factors control size of groups being fired? **STRESS** factors outlined.

Have each shooter **FIRE** a 5-shot string and **ANALYZE** each one for group size. **DO NOT** worry about group location or altering sight settings.

Have shooters with large groups **REVIEW** the keys to good shooting and **FIRE** another string from supported position.

If necessary, **REPEAT** the triangulation and trigger control exercises.

Take every precaution to **KEEP PRESSURE OFF** shooter. **ISOLATE** them for review if needed to reduce pressure.

STOP shooting session before fatigue becomes a factor.

Let shooters **LEAD** review of lesson by asking leading questions.

BE SURE to answer any questions and prepare them for next shooting session.

Lesson Narrative

Rifle shooting involves only a few factors that are important to accurate and safe shooting. Self-control is required for both purposes. That includes the ability to concentrate on the task at hand as well as complete awareness of potential dangers. There is no room for any foolishness or horse-play.

What are the three primary rules of safe shooting on the range? The most important is keeping the muzzle pointed in a safe direction at all times. In addition, keep the action open, the firearm empty and the open action exposed to view at all times. Finally, never put your finger on the trigger until in the act of shooting.

Sight alignment is lining up the eye with the bore by placing the front and rear sights in a consistent visual relationship. Proper sight alignment with these receiver sights involves centering the front sight precisely in the rear aperture. The front sight remains in focus throughout the shooting process.

Trigger control is firing the rifle without changing the sight alignment during the process. The trigger is pressed straight back until it breaks" or releases the sear to fire the rifle. During and after the shot the shooter tries to keep the sights aligned and on target.

One of the ways to ensure safety on the range is to have one person in charge. The range officer is in absolute control of the range. We use a standard set of commands to control actions on the range.

That helps us avoid confusion.

The most important command issued is "cease fire!" It brings all shooting to a complete and immediate halt. All other actions on the range follow the direction of the range officer as well. The commands we will be using include the following.

"Relay [number] or shooters to the line."

Shooter-coach pairs move to the firing line with their equipment and make all equipment safe.

"Is the line ready? Respond by firing point number, please."

Shooter or coach must respond either "ready" or "not ready."

"Pick up your rifles."

Shooters may pick up their rifles, verify that they are safe, check to be sure the safety is on and get into shooting position without loading the rifle.

"Load your rifle."

The coach will load and charge the rifle and return it to the using the proper protocols.

shooter

"Safeties off."

The coach will switch the safety to the "fire" position.



"Assume a comfortable firing position."

The coach will assist the shooter into a sound bench-rest position.

"Align your sights."

Shooters will focus on the front sight and align the rear sight with it.

"Center your sights on the target back."

Shooters will bring the aligned sights to bear on the center of the blank target.

"Press or squeeze the trigger."

Shooters will fire their rifles, keeping the sights aligned throughout the shooting sequence.

"Make your rifle safe."

Shooters will open the action, clear any ammunition, place the safety in the "safe" position and ground the rifle on the bench with the action up and the muzzle pointing down range.

Dry Firing Review

Prior to live firing, let's review the dry-firing process. The first relay of coach- pupil pairs move to the line. Once the line is ready, each shooter should cock the rifle, point it down range and squeeze the trigger to re-establish the trigger feel. Next, dry fire a round or two with the sights aligned on the backstop. Then, align the sights, center them on the blank target and dry fire another round or two. Reverse roles so both members of the team get a chance to warm up by dry firing.

Live Firing at Target Backs

Live firing involves firing a projectile at a target. The projectile leaves evidence of the point of impact, which allows the shooter to see where the bore was pointed when the rifle was fired. If the sights were properly aligned, the eye and the bore should have been looking at the same point of impact. We are not concerned with the point of impact as much as with the consistency (precision) of that point of impact. The size of the group gives evidence of consistency in form and hold. As long as it is on the paper, the location is not important.

Each action type has a specific loading procedure. We will be using bolt action, single stroke, and pneumatic air rifles for this exercise. *[Instructor note: modify this to fit the type of rifle you will be using.]* The rifle is loaded by pulling the bolt handle back toward the butt of the rifle. That cocks the rifle and opens the action to permit a pellet to be loaded through the loading port. Place the trigger safety in the "on" position by pushing the safety button from the left to right so that no red is showing. The rifle is charged by grasping the charging lever and moving it forward as far as it will go. With the fingers, out of the way, the lever is then drawn back and locked in place. The lever may close with a snap, so avoid getting your fingers pinched. The pellet is inserted in the port with its skirt (the hollow base portion) facing toward the rear and the closed end toward the muzzle. Pushing bolt forward locks the action.

Does anyone have any questions on how to cock, load or charge the rifle?

Follow these teen leaders as they demonstrate the five-firing sequence. Note that they follow the range officer's commands and keep the muzzle under control at all times. Once the range officer has declared the range hot or ready for live firing, the shooter opens the bolt and moves the safety to the "on" position. Then the rifle is charged with air by making one complete stroke with the charging lever. Throughout this operation, note that the muzzle is pointing down range and the trigger finger is kept off the trigger. The shooter then takes a comfortable bench-rest position. The rifle is now loaded and the bolt is closed. The safety is pushed to the "fire" position. Then the sights are aligned and held on the center of the target back in front of that firing point. The shooter squeezes the trigger until the rifle fires, keeping the sights aligned and centered on the target back. Note that the rifle held its position until after the pellet hit the backstop. Then the rifle is made safe by opening the action and placing it, action up, on the bench with the muzzle pointing toward the backstop.

Live Firing at Target Backs

You will note that none of the targets on the backstops have any bullseyes on them. You are shooting at the backs of the targets to check sight alignment and trigger control. If both are being used properly, and you are holding the aligned system on the middle of the target back, you should be able to shoot relatively small groups. The objective is to shoot groups. We are trying to avoid confusion by keeping you from worrying about your score.

Coaches, remember that your job is to watch for proper shooting form and safety at all times. Remember that we must always keep the muzzle pointed down range. The shooter needs to focus on the front sight, align the sights and control the trigger to shoot good groups. We will shoot the first shot in each relay on command.

"Shooters to the line."

"Is the line ready? Respond by firing point number, please." "Pick up your rifles."

"Safeties on."

"Coaches, charge rifles with air and load."

"Hand the rifles to your shooters." "Safeties off."

"Focus on the front sight and align the sights."

"Center the sights on the target back, keeping the front sight in focus." "Squeeze the trigger, keeping the sights aligned and centered on the target back until the pellet hits the backstop."

"Make your rifles safe by putting the safety on, opening the action and placing the rifle on the bench with the action exposed to view."

"Coaches, you may continue to load and let your shooter fire several more rounds."

Once the first shooter in the team has had a chance to fire three to ten rounds, the team members should reverse roles and repeat the entire sequence. If other relays are waiting, have this relay evaluate what they learned and review shooting procedures while the others shoot. If no other relay is waiting, continue the firing process, reversing roles after every five to ten shots. Watch for fatigue and try to take breaks before it becomes a problem.

Shooting a Group for Analysis

Now that we have all had a chance to shoot at a target back, let's put up fresh targets and shoot a series of five shots to see how tight a group you can shoot. Remember to keep the same point of aim on the center of the target back regardless of where the shots are hitting. The size of the group will depend upon your consistency. Consistent sight alignment with a consistent trigger squeeze and a consistent sight

picture on the target back will give you the smallest possible group. Go ahead and shoot five shots at your target, trying to do your best.

Retrieve your targets, and bring them to your instructor. Small groups indicate that you have mastered the basics of firing a shot adequately to go on to the next step. Instructors, if necessary use the triangulation exercise to evaluate sight alignment or the trigger control exercise with your shooters who are shooting large groups. (An explanation of how to do the triangulation exercise can be found in the narrative of Lesson 4 *Teaching Sight Picture*.) Remember that the location of the group is not important. Only its size is important right now.

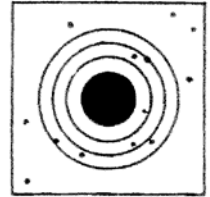

Summary

What have we learned today? It is much easier to hit the same hole every time when we dry fire than when we are actually shooting projectiles down range. Tight groups are the result of consistent sight alignment, consistent trigger control and a consistent hold on the target. These few fundamentals can help you shoot small groups. Small groups make it possible to adjust the sights so the sights and the bore are pointed at the same location. Be sure to write the things you have learned in your shooting journal or notebook.

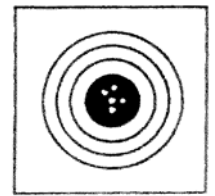

Summary Activities

1. Have shooters compare the first groups they fired with the last one. Discuss the reasons they feel are important in causing those differences.
2. Use the triangulation exercise to evaluate sight alignment.
3. Have shooters write what they learned in this lesson in their shooting journal or notebook.

Sharing and Exhibit Ideas

1. Make a step-by-step poster or series of posters depicting the shooting process to be used in teaching.
2. Display your shooting journal with a series of targets, group sizes or other indications of changes in shooting ability.
3. Make a rifle rest that can be used in the bench-rest position.
4. Make a shooting bench that can be used in bench-rest shooting.

Teaching Sight Picture

Ronald A. Howard Jr., William F. Stevens, John Kvasnicka and Marilyn Bergum*

Objectives

Participating youth and adults will:

1. Understand the concept of sight picture.
2. Demonstrate the ability to shoot groups by using consistent and proper bench-rest shooting position.
3. Demonstrate ability to adjust sights properly to move the point of impact to a desired location.
4. Understand the relationship between sight alignment and sight picture.
5. Understand and use triangulation.
6. Have fun while learning.

Roles for Teen and Junior Leaders

- Demonstrate sight adjustment.
- Assist shooters with sight adjustment.
- Demonstrate sight picture and illustrate need for consistency.
- Assist with range management.
- Act as assistant instructors or range officers.
- Teach portions of the lesson.
- Assist shooters with triangulation exercise.

Parental Involvement

- See Roles for Teen and Junior Leaders above
- Provide or arrange for transportation.
- Provide or arrange for refreshments.
- Interpret targets and aid with sight adjustment.
- Score targets.
- Assist with fun shooting.

Best Time to Teach

Any time of year, but after shooting groups on target backs

Best Location

Any safe shooting area

Time Required

Approximately 1 hour

Materials/Equipment

- rifles
- shooting bench with pad and seat
- eye and ear protection
- ammunition
- targets
- safe backstop
- sandbags
- dummy or inert ammunition
- manufacturers' ammunition and ballistics catalogs
- visual aids for sight picture (Models, diagrams or posters)
- open bolt indicators

References

The Basics of Rifle Shooting.
B. W. Sheets, National Rifle Association, Washington, DC.1987. *NRA Junior Rifle Shooting.*

G. Anderson. National Rifle Association, Washington, DC. 1983.

Four-in-One Shooting Instruction DVD Basic Rifle Shooting - A Better Way.

Contact your state coordinator or Federal Cartridge Co. Anoka, MN.

* 4-H and Youth Development Specialist, Texas Agricultural Extension Service; Conservation Affairs Manager for Federal Cartridge Company, Anoka, MN; Executive Director, Minnesota Deer Hunters Association; and National Rifle Association Field Representative to Minnesota, North Dakota and South Dakota

Teaching Outline

Presentation

I. Review

- A. Safety
- B. Eye and ear protection
- C. Range commands and control
- D. Shooting procedures
- E. Dry fire
- F. Dry fire at target backs

II. Review live firing at target backs

- A. Refreshing the basics
 1. Sight alignment
 2. Trigger control
 3. Consistency for groups
- B. Review of basic shooting position

III. Learning sight picture

- A. Define sight picture
 1. Aligned sights in relation to a target
 2. Elements of proper sight picture
 - a focus on front sight
 - b rear sight and target slightly blurred
- B. Variations in sight picture
 1. Types of sight picture
 - a center-of-mass
 - sights aligned with the intended point of impact
 - b six o'clock hold
 - entire bulls eye on top of the front sight
 - "pumpkin on a post"
 - c both acceptable
 - stick with one method
 2. Sight pictures with different types of sights
 - a telescopic sight
 - reticle and target in focus
 - cross-hair, top of post or dot on intended point of impact

Application

Use **QUESTIONS** to have young people **SUMMARIZE** previous lessons. **REINFORCE** all major points of emphasis.

SHOOT at least one series of shots for each shooter using target backs to relieve trigger feel and sight alignment.

USE sighting device or model to illustrate sight picture and variations with different types of sights.

SHOW difference between center-of-mass hold and six o'clock hold. **DISCUSS** advantages and drawbacks of both types.

STRESS sticking with one type of hold once you have tried them.

USE models or illustrations of various reticles to **SHOW** relationship of reticle to target. **USE** illustrations or models to **SHOW** sight pictures with receiver sights.

- peep or aperture rear sight
 - post or bead front sight
 - * center-of-mass hold
 - aperture front sight
 - * centered in front aperture
 - * center-of-mass hold
- open rear sight
 - center-of-mass hold
 - six o'clock hold

IV. Live firing at target faces

- A. Maintain proper bench rest position
- B. Live fire by commands
 1. Use expanded range commands
 2. Reinforce proper shooting procedure
- C. Fire three to five shots
- D. Reverse roles and repeat exercise
- E. Repeat the exercise two or three times
 1. Do not adjust sights
 2. Keep constant sight picture
 3. Shoot for groups

V. Developing consistent sight pictures

- A. Triangulation exercise
 1. Set up simulated rifle in box, cradle or vise
 2. Adjust simulated rifle position to target
 3. Tape simulated rifle and supports in place so they cannot be moved
 4. Shooter aligns sights
 5. Assistant moves "bull" until "shooter" calls the shot
 - a shooter directs movement until bull is in position
 - b assistant marks through center of bull with pen or fine marker
 - c repeat the procedure at least three times with each shooter
 6. Size of triangle indicates consistency (precision) in sight picture

Move back to range and have each shooter **FIRE** several groups at bulls eye targets, taking turns and being careful to **AVOID** fatigue.

WATCH for development of tight groups, but **DO NOT MOVE** sights.

Note: Training Aid -Simulated Rifle can be made using a 1" X 3" X 3' wooden board with a front and rear sight mounted to the narrow side of the board.

ILLUSTRATE properly aligned sights and sight pictures once more.

NOTE that kids who have difficulty attaining good sight pictures should **REVIEW** the basics of sight alignment.

PROVIDE a non-threatening site for them to practice until they obtain groups that are about dime-sized. Poor vision may cause problems for some young people who are not aware of their visual difficulty.

VI. Sight adjustment

- A. Objective is to bring point of aim and point of impact together
- B. Sights moved into alignment with the bore
 1. Group center as reference point for sight adjustment
 - a average point of impact
 - b considers variation in hold and rifle performance
 2. Adjustment in two planes
 - a windage - horizontal location adjustment
 - b elevation - vertical location adjustment
- C. Methods of adjusting sights
 1. General rule for sight adjustment
 - a move rear sight in the direction you want the point of impact to move
 - if group must be moved to the right, move the sight to the right
 - if group is low, raise the rear sight
 - b move front sight toward the point of impact
 - if group is to the left, move the front sight to the left
 - if group is low, lower the front sight
 2. Telescopic sights or receiver sights with micrometer adjustments are easiest to use
 - a markings or click stops at relatively even intervals
 - check manufacturer's instructions
 - note changes for your rifle and sights
 - b increments of change expressed in minutes of angle (MOA)
 - 1 MOA
 - 1 inch at 100 yards
 - 1/2 inch at 50 yards
 - 1/6 inch at 50 feet
 - * many sights as fine as 1/4 MOA per mark or click
 3. Adjusting telescopic or peep (receiver) sights with micrometer knobs
 - a adjustment directions marked on knobs or dials
 - b fire three to five shots using the same sight picture
 - c measure vertical and horizontal changes needed
 - d estimate number of clicks

USE illustrations of groups on targets, or use large targets with stick on dots, to show how to adjust sights. If a good shooter is available, try **DEMONSTRATING** impact movement with sight adjustment.

DEMONSTRATE sight adjustment on rifles being used. **DISCUSS** other types of sight adjustment **ONLY** if asked or they are being used in course.

SHOW minute of angle in illustration to show that changes vary with distance from muzzle.

Have teen or junior leaders **HELP** pairs of shooters with their first sight adjustment.

STRESS importance of recording amount of change each click at different ranges in shooting journal.

- e move sight in direction you want point of impact to move
- f record the number of marks or clicks the sight was moved
- g fire three to five more shots using the same sight picture
- h check location of group center, note amount of change per click or mark and correct by trial and error

D. Adjusting open sights

1. May use screws, wedges or a punch
2. Basic procedure similar to telescopic or micrometer adjusted peep sights
 - a fire a three- to five-shot group
 - b use center of group as a reference point
 - c move rear sight in the direction hits must move and record the sight change
 - d fire another three- to five- shot group using the same sight picture
 - e record distance moved for amount sight was moved
 - f estimate sight movement needed and move sight
 - g refine location by trial and error
3. Front sight adjustment is in opposite direction - move toward existing point of impact

EMPHASIZE staying with process until satisfied.

VII. Summary

- A. Combining sight alignment with target for sight picture
- B. Repeating the basics of firing a shot
- C. Adjusting the sights for accuracy

REVIEW the main topics covered in this lesson, letting the young people lead the session by asking questions.

Lesson Narrative

Before we get started with this lesson, let's review material we have covered on safety and marksmanship. Each shooter is responsible to all others on the range for his or her actions. The shooter alone controls the direction the rifle is pointed. That makes each shooter responsible for obeying all range safety and procedure commands and abiding by the protocols of good sportsmanship. Firearms are inspected by both the shooter and the range officer to assure safety. However, the shooters must practice self-control, muzzle control and trigger control at all times. We follow three basic rules to assure others on the line that each rifle is safe. The muzzle remains pointed in a safe direction at all times. The rifle remains empty with the action open and exposed to view except when it is being fired. The finger is kept off the trigger except when in the act of shooting. In addition to those firearms handling rules, each person on the range must have adequate eye and ear protection when live firing takes place.

The fundamentals of marksmanship have been established as well. We have learned proper sight alignment and the reasons for using consistent sight alignment. Trigger control is exercised to fire the rifle without disturbing the sight alignment. Follow through is critical to good shooting form. Finally, we learned to assume a stable bench rest shooting position. We practiced loading and unloading the rifles properly, and used both dry-firing and live-firing techniques to practice shooting on blank targets or target backs.

Join your partners, get your equipment and move to the line. Remember to keep the muzzles pointed in a safe direction with the actions open and the rifles empty. The range officer will check each one on the way to the firing line. Coaches, put your rifles in the racks until you change roles. Once your rifles have been grounded, hang a target with the back facing the shooter. On command, shoot a five- shot group at the target back, being careful to use proper shooting form as you fire your group. After the first relay fires, we will clear the line, reverse roles and let the second relay fire their refresher shots.

Sight Picture

A sight picture is a properly aligned set of sights in relation to a target. Proper sight alignment is essential for developing a sight picture. Throughout the sighting sequence, the eye should remain focused on the front sight. The rear sight and target will both be slightly out of focus. Once the sights are properly aligned, they are moved as a unit into proper position relative to the target.

Two basic types of sight pictures are used in precision shooting, the center-of-mass hold and the six o'clock hold. With the center-of-mass hold, the aligned sights are centered on the intended point of impact. The bullet should strike precisely at the top of the post, the

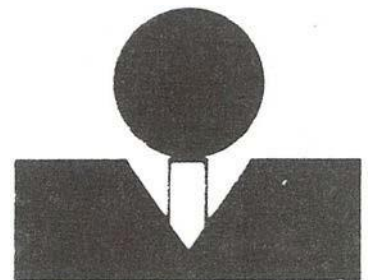

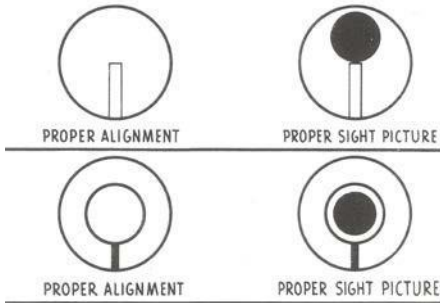

center of the aperture, or the center of the telescopic sight's reticle. With the six o'clock hold, the entire bull is centered on the top of the front sight. This "pumpkin on a post" sight picture is considered somewhat more precise with a bead or post front sight. Many shooters prefer to see just a hair's breadth of lighter colored material between the top of the sight and the bottom of the bull. They feel it helps to keep them from drifting up into the bull slightly.

Both types of sight pictures have advantages and disadvantages. The six o'clock hold gives a somewhat more precise aiming point on a target. The exact location of the bull relative to the sight is easy to see, and the target is not obscured by the sights. In field shooting, no bull is present; and it may not be clear where to hold on the game animal relative to the top of the sight. The center-of-mass hold allows easier positioning of the sight on the game animal or target. In some cases a large portion of the target is obscured by the sight while aiming. In field shooting, however, the point of impact on the animal is fairly clear and evident. Both types of hold or sight pictures are acceptable. Try them. See which one you prefer (which one fits your purposes and gives you better results) and stick with it. NEVER change sight pictures during a series of shots being fired as a group.

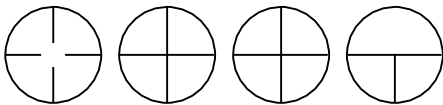

Sight pictures differ slightly with different types of sights. With telescopic sights, the optics cause both the reticle and the target to appear on the same plane. That leaves both of them in sharp focus. The cross-hair, top of the post or dot is placed on the intended point of impact. With receiver sights (peep or aperture rear sights), a front post or bead is held either on the center-of-mass (the intended point of impact) or at the bottom of the bull (six o'clock hold). With an aperture front sight, the target is centered in the front aperture, just as the front aperture is centered in the rear one. With open rear sights, most shooters prefer a six o'clock hold; but a center of mass hold is also acceptable. The main thing to remember is to stick with one type of sight picture once you have decided which one gives you the best results.

Shooting at Target Faces

Now let's return to the shooting line. First relay to the line. Assume a bench-rest shooting position. Is the line ready? Respond by firing point number, please. The line is ready. Shooters, verify that your rifles are empty, leave the actions open and check to be sure the safety is on. Coaches, verify the safety of each rifle. Charge the rifle with air if needed and load. Coaches may assist with this operation. Align the sights properly. Remember to keep your eye focused on the front sight and to position the front sight in

proper relation to the rear sight. Obtain the desired sight picture. Move the rifle rest or sandbags if necessary to obtain the sight picture. Switch the safety to the “fire” position. Squeeze the trigger, keeping the sights aligned and the sight picture stable. Hold the sight picture until the bullet or pellet strikes the backstop. Move the safety to the “on” or “safe” position. Open the action and make the rifle safe, keeping the muzzle pointed down range. You may fire three to five more shots. Remember to keep the same sight picture for each shot. Cease fire. Open all actions and make your rifles safe. Ground your rifles after they have been made safe and step back one step from the bench. Change roles within the coach-pupil team and repeat the entire exercise. Remember that we will fire the first shot on commands.

This live firing exercise should be repeated several times without adjusting the sights (as long as the shots are printing somewhere on the target face). The object is to have each shooter fire a relatively small group that can be used as a foundation for sight adjustment.

Triangulation Exercise

The objective of this exercise is to check the precision or consistency of the shooters sight alignment and to develop a proper sight picture. Each rifle has been made safe, with the bolt removed and an open bolt indicator installed. The rifle is secured in a rest anchored to a shooting bench. The rifle is adjusted in the rest so that it points at a blank sheet of paper on the wall between 25 – 50 feet away from the rifle muzzle. Without touching or moving the rifle’s supports, the shooter looks through the sights and aligns them. Then he or she directs the range assistant to move the “bull”(the bull is a single bullseye target with a small hole poked in the ten ring) until it forms a proper sight picture with the aligned sights. The assistant will mark the location through a tiny hole in the bull. Repeat the process at least three times. The size of the triangle or group indicates the degree of precision used in aligning the sights and the shooters understanding of obtaining a consistent sight picture. Sight alignment has a much greater impact on the size of the group than does sight picture. Shooters experiencing difficulties with sight alignment and sight picture should participate in this exercise with a range assistant as needed.

Sight Adjustment

The sights align the eye with the bore of the rifle. If the sights are not aligned with the bore, the point of impact does not match the point of aim. The point of aim must be moved to coincide with the point of impact. In other words, the sight must be aligned with the bore. The center of a group of shots fired with the same sight setting and the same sight picture is used as a reference point in adjusting the sights. That takes into account the variation in sight alignment, sight picture and in the rifle itself.

The sights are adjusted in two planes. The horizontal (right and left) adjustment is known as **windage**. The vertical (up and down) adjustment is called **elevation**. Although it seems to be moving in the wrong direction, the basic rule in sight adjustment is to move the rear sight in the direction you want the point of impact to move.

Sights are adjusted in several different ways. Telescopic sights and receiver sights with micrometer adjustment have windage and elevation adjustment knobs. The knobs may have positive click stops or lines used as a reference in sight adjustment. The approximate value of each mark or click should be listed in the instruction manual with the sights, but a better value can be determined by field testing. Every time you adjust the sights, you should note how much movement of the point of impact you got for each click or line of adjustment in the sights. Remember, the adjustments are in minutes of angle. That means that they will change in absolute value with changing distance. One minute of angle (MOA) equals one inch at 100 yards or approximately 28 mm at 100 meters. A one MOA adjustment at 50 yards would only move the point of impact 1/2 inch. At 50 feet that movement would only be about 1/6 inch. Since many sights have divisions that allow adjustments as fine as 1/4 or 1/8 MOA, the shooter can make extremely small corrections in sight settings when needed.

The general procedure for adjusting sights or sighting in a rifle involves repetition in a trial and error process. First, fire a three- to five-shot group using the same sight setting and sight picture. Measure the vertical and horizontal distances from the center of the group to the point of aim or intended point of impact. Estimate the number of clicks or lines that the sights will need to be moved in each direction to reach that desired point. Move the sights and record the amount and direction they were moved. DO NOT forget this step. It is very important both now and in the future. Fire a second group (three to five shots) using the same sight picture. Note the new location of the group center. Using the amount the sight was moved and the distance the hits were moved, calculate how much more the sights need to be moved and in which directions. Repeat the process of adjusting the sights and shooting groups to verify their settings until the group is centered on the intended point of impact. Stay with it until you are satisfied.

Some open rear sights must be adjusted with uncalibrated screws or wedges. Others may be moved only by drifting them into a new location with a punch. Some primitive sights were adjusted by means of a small file. The principles are the same, but the precision of the adjustments may be a bit crude.

Very few rifles require adjustment of the front sight. If front sight adjustment is necessary, the sight should be moved toward the existing point of impact. Archers, who use an adjustable front sight, refer to this as “chasing the hits with the sight.”

Adjusting the Sights on Your Rifle

Let's apply this information on sight adjustment to the sights on the rifles you are using. Use the groups you have shot earlier to determine the direction and the amount you should move your sights. Work as a coach-shooter pair on the adjustments, and discuss the adjustments needed with a teen leader or an adult range assistant. Make the sight adjustment, keeping the muzzle of a safe rifle pointed down range. [Use standard range commands to control the range throughout this exercise.] Once you have finished adjusting the sights on your rifle, switch roles with your partner and assist them with the process.

Summary

This lesson taught us how to combine sight alignment with the target for a proper sight picture. We reviewed the process of firing a shot, then fired groups on a standard target, and learned how to adjust the sights for accurate shot placement. Next session we will fire a short match from the bench-rest position and learn how to score targets.

Summary Activities

1. Have each shooter evaluate a group and estimate how many clicks they would need to move their sights to adjust the point of impact to the center of the bull.
2. Have each shooter record the sight adjustments they made and the distance the point of impact moved for that adjustment in their shooting journal. Help them to figure out how large the movements would have been at a different distance.

Sharing and Exhibit Ideas

1. Shoot a series of groups, moving the sights a set number of units with each group. Note how much change in the point of impact results from each unit of change in the sight setting.
2. Demonstrate how to adjust the sights on a rifle, using a series of targets to show how the adjustments moved the point of impact.
3. Make a model to illustrate how sight adjustments are made and how they correct the point of aim to the point of impact.
4. Share what you have learned about sight picture and sight adjustment with an interested adult.

Shooting for Scores and Scoring Targets

Ronald A. Howard Jr., William F. Stevens and John Kvasnicka*

Objectives

Participating youth and adults will:

1. Demonstrate proper sight adjustment on their rifles.
2. Fire a modified ten-shot match from the bench-rest position.
3. Practice scoring targets.
4. Have fun while learning.

Roles for Teen and Junior Leaders

- Review sight adjustment.
- Review range safety.
- Act as assistant range officers.
- Demonstrate proper use of scoring gauges.
- Assist with or verify scoring.
- Assist any shooter or coach having difficulties.

Parental Involvement

- See Roles for Teen and Junior Leaders above.
- Act as statistical officers for the shoot.
- Provide or arrange for shoot trophies or prizes.
- Prepare targets for the match.
- Arrange for or provide transportation.
- Arrange for or provide refreshments.
- Plan for a fun shoot.

* 4-H and Youth Development Specialist, Texas Agricultural Extension Service; Conservation Affairs Manager for Federal Cartridge Company, Anoka, MN; and Executive Director, Minnesota Deer Hunters Association.

Best Time to Teach

Any time of year, but before teaching positions other than the bench-rest position

Best Location

Any safe shooting range with a bench

Time Required

About 1 hour (repeat as needed)

Materials/Equipment

- rifles
- ammunition
- eye and ear protection
- standard targets
- bullet blocks
- sandbags or other riflerests
- shooting benches with pads
- benches or chairs for shooters
- appropriate target hanging materials
- targets (AR5/10 or A17) with backer board for demonstration
- appropriate inward and outward scoring gauges
- pencils or pens
- pads or scoring sheets
- fired targets for scoring practice
- open bolt indicators

References

NRA Junior Rifle Shooting.
G. Anderson. National Rifle Association, Washington, DC. 1983.

The NRA Junior Rifle Handbook.
G. Anderson. National Rifle Association, Washington, DC. 1983.

The Basics of Rifle Shooting.
H. W. Sheets.
National Rifle Association, Washington, DC. 1987.

NRA Smallbore Rifle Rule Book (or other appropriate rule book).
National Rifle Association, Washington, DC.

Teaching Outline

Presentation

I. Review

- A. Safety rules
- B. Eye and ear protection
- C. Sight alignment
- D. Sight picture
- E. Trigger control
- F. Range commands
- G. Shooting procedures
- H. Sight adjustment

II. Reviewing sight picture and sight adjustment from the bench

- A. A Dry fire several “shots”
 1. Use expanded range commands
 2. Use standard target
 3. Reinforce sight alignment, sight picture and trigger control
- B. Fire a three- to five-shot group
 1. Maintain bench-rest position
 2. Maintain consistent sight picture
- C. Adjust sights to center group on sighting bull
 1. As many shots as needed
 2. Help any shooter having difficulty
- D. Reverse roles and repeat sequence

III. Shooting for score

- A. Replace sighter targets
- B. Note purpose of central bulls
 1. Sighter shots
 2. No limit on sighters
 3. Time limit for match
- C. One shot each on record bull
 1. Importance of a system
 2. Use of a loading block
 3. Observation by “coach”
- D. Replace targets, switch roles and repeat exercise

IV. Mechanics of scoring targets

- A. Center scores a 10
 1. Dot in center of smallbore 50- foot position target and 10- meter air rifle target
 2. White spot on light rifle target
 3. Center shots or X’s

Application

REVIEW major points of preceding lessons using **QUESTIONS** to stimulate shooters' thoughts.

Have each shooter **DRY FIRE** a few shots on a standard target using expanded range commands.

Have each shooter **FIRE** three to five shots from bench-rest position at sighting target.

Allow shooters to **ADJUST** sights during this refresher of last meeting. **PROVIDE** help for any shooter needing it.

Have each shooter **FIRE** ten record shots, moving clockwise around target face. **ALLOW** about 20 minutes to complete course of fire unless all shooters finish earlier. **ENCOURAGE** them to take their time and **SHOOT** carefully.

Use carefully selected targets or illustrations of targets to **ILLUSTRATE** how to score them.

- B. Bands in descending value
 1. 9-8-7-6-5-4-3-2-1
 2. Ring part of higher value band
 3. Touching ring gets higher value
 4. No value outside scoring area
 5. Center shots remove dot
 6. Excess hits on bull
 - a. loss of higher value hit
 - b. assignment to un-hit bull
 - penalty point for excess hit
 - only if proper number of shots are on target
- C. Excess hits on target
 1. check for cross-firing
 2. score as for excess hits on a bull
 3. do not reduce score below zero
 4. allowance for first sighting shot if called and signed
- D. Use of scoring gauge or plug
 1. Purposes
 - a. assists in locating the hit accurately
 - b. relate hole location to a larger ring
 - c. clarifies close shots
 2. Inward gauges
 - a. touching inner line gives higher scoring zone value
 - b. used as outward gauge for center shots
 3. Outward gauge
 - a. easier for scoring tens
 - b. references on 7 ring

V. Scoring your targets

- A. Scoring without gauges
 1. Score several targets
 2. Record shooter name or target number
 3. Record scores for each bull and total for target
- B. Scoring with scoring gauges
 1. Observe teen leaders or adult scorers using gauges
 2. Check “plugged” hits for score
 3. Compare your scores with the verified ones
 4. Practice using scoring gauges on the targets provided

VI. Summary

- A. Review of sight alignment and sight picture
- B. Introduction to a match setting
- C. Scoring and the use of scoring aids
- D. Introduction to the standing position next time

PROVIDE some pre-selected targets to challenge young people in their scoring process.

SHOW how a backer target can reveal a shot from another firing point.

DEMONSTRATE and have shooters **PRACTICE** using inward and outward gauges.

SCORE targets shot in this exercise twice in small groups with teen leader or adult supervision, first without any scoring aids, then with gauges.

ALLOW shooters to use several types of scoring devices, if available.

REVIEW fundamentals of shooting and scoring process.

PREPARE shooters to learn standing position in next session.

Lesson Narrative

Before we begin shooting today, let's review the fundamentals we have already learned. We will continue to follow the rules of safe shooting on the range, including using eye and ear protection. Proper sight alignment is fundamental to development of a sight picture, breath control, trigger control, and follow through is essential for accurate shooting. We have learned to follow range commands, and we will continue to use the expanded ones for this session. Finally, we learned last time how to adjust the sights on our rifles to center the point of impact on the desired spot.

Sight Picture and Sight Adjustment from Bench

[Instructor note: Use the expanded range commands to bring the first relay of shooters and coaches to the line. Have them dry fire several shots on a standard target while reinforcing sight alignment, sight picture, breath control, trigger control and follow through. Once they have dry fired a few shots, move on to live firing and fine tuning their sight adjustment.]

Adjusting the Sights on Your Rifle

Now, fire a three- to five-shot group using a consistent sight picture. Use that group center to adjust your sights. Check them by firing several more shots until you are satisfied with the adjustment. Discuss any questions with your "coach" and a teen or adult leader. Be sure to keep the muzzle down range during all adjustments. Once you have finished adjusting your sights, switch roles and let your partner adjust the sights on his or her rifle.

[Instructor note: Use standard range commands to control the range throughout this exercise. If each pair of shooters will be using the same firearm, have the first shooter fire a record target before switching roles and repeating the process.) Once you have finished adjusting the sights on your rifle, switch roles with your partner and assist them with the process.

Shooting for Scores

Now that you have adjusted your sights we will be shooting one ten-shot target for scoring. Mark a target with your name and hang it on the target frame. Use the center bulls, the ones with the line around them, as sighting targets if you feel the need. Shoot only one shot at each of the scoring bulls on the target, moving clockwise around the target face. Use a loading block to keep track of the shots you have fired, and be sure you are shooting at the proper target. Once you have completed your string of shots, switch roles and observe or spot as your partner shoots his or her scoring shots.

[Standard range commands should be used to operate the range during this shooting session. Allow approximately 20 minutes for the series of 10 shots, but if all shooters finish early be prepared to move on to the next session.]

Scoring Targets

Each scoring target has a maximum value of 10 points. The tiny dot in the center of the air rifle or smallbore target has the value of 10. Shots that remove the dot are center shots or X's. Each consecutive scoring band is

worth one less point than the one inside it, so the target scores 10-9-8-7-6-5- 4-3-2-1. The ring between the dark bands is part of the higher value scoring area. Any shot touching the ring is given the higher score. Shots that fail to touch any of the scoring area are given a value of zero.

Sometimes a shooter gets confused and fires extra shots at one bull without firing at another one. If the target has only the proper number of record shots, the extra shot is penalized one point and referred to the bull that was not fired upon. If excess shots are taken on the target, the shooter loses the higher value hit on each target with multiple shots, even if that shot is outside the scoring area. If those excess shots were fired by another shooter (cross-firing), they are not counted against the shooter and are recorded as misses for the person who fired them. If the first sighting shot falls outside the sighting area and the shooter indicates that it did so, it is not counted as an excess record shot.

Scoring a target can be challenging. Holes may not be cleanly cut, and the exact edge of the bullet hole may be unclear. Scoring gauges or plugs are extremely valuable in that situation. An inward scoring plug indexes in the bullet hole and shows where the edge of the bullet struck. If the edge of the gauge or plug touches the scoring ring, the shot is given that value. Inward scoring gauges are also used to determine center shots. If the flange of the gauge does not touch the 9 ring, the shot is scored as a center shot. An outward scoring gauge makes determining “tens” easier. It uses the 7 ring as a reference. If any of the 7 ring is visible, the shot counts as a 10. If the flange obscures the 7 ring, the shot counts as a 9.



Scoring Your Targets

Each of the scoring bulls on the target you shot is worth 10 points, so your total possible score could be as high as 100 points. Do not worry about the score you made. You should record it in your shooting journal, but our main objective is to learn how to score a target.

Score several targets in a small group. The first time through, score them without using any type of scoring aid. Record the scores on your pad, listing each bull by number and score. Then score them again using the scoring gauges. Work with an adult or teen leader to verify your scores. While the scores are being posted, you may want to try scoring several other targets using the gauges.

Summary

In this session we reviewed sight alignment, sight picture and trigger control. We sighted our rifles to place the center of their groups on the center of the bull, and fired a ten-shot match from the bench-rest position. We also learned how to score targets and how to use scoring aids. The next session will start teaching the basic shooting positions, using the standing or off- hand position.

Summary Activities

1. Have each shooter shoot a series of ten shots on a standard target and score their target. Be sure to have them record their scores, sight adjustment measurements and other new items they learned in this session in their shooting journals.
2. Provide a group of targets for scoring. Have each shooter score the set, and compare their scores. Provide scoring aids and have them repeat the scoring as a group. Note how the scoring changed on some close shots.
3. If time permits, allow shooters to fire an additional match from the bench-rest position. Have them compare their scores from the two matches and try to determine why any differences exist.

Sharing and Exhibit Ideas

1. Demonstrate how to score a target.
2. Demonstrate the proper use of inward and outward scoring gauges.
3. Record the scores fired and the things you learned in your shooting journal. Display the journal or discuss the contents with an interested friend or adult.
4. Look up a target shooting game fired with air rifles or smallbore rifles. Discuss the targets used and the rules. Outline the game for your shooting group, or share your findings with an interested person.

Standing Positions

John Kvasnicka, William F. Stevens and Ronald A. Howard Jr. *

Objectives

Participating youth and adults will:

1. Understand and practice the arm-rest standing rifle position.
2. Understand and practice the free-arm (off-hand) standing rifle position.
3. Understand and practice the principle of skeletal support in the standing position.
4. Practice safe range and shooting procedures.
5. Practice peer coaching on the firing line.
6. Have fun while learning.

Roles for Teen and Junior Leaders

- Demonstrate the standing positions.
- Demonstrate use of the rifle stand or support.
- Act as range officers or assistants.
- Assist shooters in attaining a proper standing position.
- Assist any shooter having difficulty with his or her position.

Parental Involvement

- See Roles for Teen and Junior Leaders above.
- Monitor one or two shooting positions as assistant range officers.
- Score targets.
- Arrange for or provide refreshments.
- Arrange for or provide transportation.

- Executive Director, Minnesota Deer Hunters Association; Conservation Affairs Manager for Federal Cartridge Company, Anoka, MN; and 4-H and Youth Specialist, Texas Agricultural Extension Service.

Best Time to Teach

Any time of year, after basics of firing a shot from the bench are mastered and prior to teaching the other positions

Best Location

Any safe indoor or outdoor range

Time Required

About 1 hour (repeat as needed)

Materials/Equipment

- Rifles
- Ammunition
- eye and ear protection
- targets
- tape or clips to hang targets
- adequate backstop
- rifle stand or support
- open bolt indicators

References

NRA Junior Rifle Shooting. G. Anderson. National Rifle Association. Washington, DC. 1983.

The NRA Junior Rifle Handbook. G. Anderson. National Rifle Association. Washington, DC. 1983.

The Basics of Rifle Shooting. H.W. Sheets. National Rifle Association. Washington, DC. 1987.

Student Handbook for Junior Position Air Rifle. Lt. Col. L. Lujan, ed. National Guard Marksmanship Center. Camp Robinson. North Little Rock, AR.

Teaching Outline

Presentation

I. Review

- A. Shooting and personal safety
- B. Sight alignment
- C. Trigger control
- D. Sight picture
- E. Range commands and shooting procedure
- F. Sight adjustment
- G. Scoring targets

II. Shooting positions

- A. Posture of the body and rifle during the act of shooting
- B. Body position considerations
 1. Comfortable and relaxed
 2. Maximum skeletal support
 3. Alignment with target
- C. Types of positions
 1. Bench-rest
 2. Standing
 - a. arm-rest
 - b. off-hand
 3. Kneeling
 4. Sitting
 5. Prone
 6. Supported positions
- D. Learning sequence
 1. Standing
 2. Kneeling
 3. Sitting
 4. Prone
- E. Reasons for using sequence
 1. Each position has more support that the previous one
 - a. increased stability
 - b. better groups and scores
 - c. higher achievement
 2. Confidence and learning increased

III. Learning the standing position

- A. Arm-rest standing position
 1. Proper body position
 - a. feet shoulder width apart
 - b. shoulders pointing to target
 - c. weight equally distributed
 - d. head and body erect
 - e. upper part of non-dominant arm against chest

Application

LEAD brief discussion focused on major elements of preceding lessons.
REINFORCE any major points not covered by shooters.

DEFINE shooting position.

ASK shooters what would make a shooting position effective. **STRESS** these points.

DEMONSTRATE or illustrate each position without equipment.

DISCUSS relative stability and uses of each one.

NOTE that supported positions are used mostly by field shooters. **POINT OUT** reason for teaching positions in this sequence.

DISCUSS skeletal support rather than using muscles for support.

Discuss positions and have volunteer or teen leader **DEMONSTRATE**.

2. Proper rifle position
 - a. butt in shoulder pocket
 - b. butt aligned so sights at eye level
 - c. dominant side hand on rifle grip
 - d. non-dominant hand under forend
 - e. use of rifle stand
3. Alignment with target
 - a. vertical adjustment
 - muscle movement
 - hand position on stock
 - body posture
 - b. horizontal adjustment - moving the feet
 - c. natural point of aim on target
4. Dry fire
5. Live firing on target face
 - a. Shoot for group on one bull
 - b. Rest between shots
6. Reverse roles and repeat
- B. Free-arm (off-hand) standing position
 1. Similar to above
 2. Upper arm clear and not supported by body
- C. Supported-standing position
 1. Body position as above
 2. Rigid object for support
 - a. non-dominant hand as a cushion
 - b. increased support and accuracy
 3. Hunting or field shooting position

IV. Summary

- A. Introduction to positions
- B. Standing position
 1. Arm-rest position
 2. Off-hand position
 3. Supported-standing position
- C. Alignment of body and target
- D. Natural point of aim

DEMONSTRATE raising butt on shoulder to bring sights to eye level.

DEMONSTRATE palm-rest, fist and fingertip rests, as well as open hand.

DEMONSTRATE use of a rifle stand and discuss reasons for using one.

DISCUSS merits of each type of vertical adjustment.

STRESS moving feet so target is on natural point of aim.

USE standard range commands and procedures. **STRESS** proper position and skeletal support. **FIRE** five-shot group at one bull.

STRESS importance of **RESTING** between shots.

USE standard range commands and firing procedures. **DEMONSTRATE** classic off-hand position. Do **NOT** fire from this position.

DEMONSTRATE supported-standing position.

Have shooters **FIRE** another five-shot group using post or other structure. **COMPARE** group to one fired earlier. **ASK** why hunters might prefer supported position. **STRESS** making clean kills.

USE questions to review material covered during this teaching session.

PREPARE shooters for kneeling position (kneeling roll needed) next

Lesson Narrative

All of the principles of firearms safety and personal safety we have practiced in our earlier sessions continue to apply. Self-control, muzzle control, action open and exposed on an empty rifle and finger off the trigger have become practiced habits for safety. You should feel partially undressed without eye and ear protection properly in place. You are the one responsible for safety on the range and the range staff will help to keep shooting safe for all of us.

The fundamentals of good rifle shooting are simple, and we have practiced them many times. Sight alignment, sight picture, breath control, trigger control, and follow through are the core of good rifle marksmanship.

The range commands that govern activity on the range should be familiar enough that anyone of you could act as a range officer. The expanded range commands and shooting procedures we have been using are also very familiar, and they should help you shoot better.

Sight adjustment has been introduced, and you have had a chance to practice it several times. In the last session, we fired a match from the bench-rest position and scored those targets, learning how to use scoring gauges or plugs. Now we are ready to introduce the classic rifle shooting positions.

Shooting Positions

Rifle shooting positions refer to the posture and attitude of the body and the rifle during shooting. Several common characteristics are common to all sound shooting positions. They form the foundation of good shooting. The body should be comfortable and relaxed. Most of the support for the rifle should come from the skeleton or bones, with minimum muscle activity and potential joint movement. The body should be aligned with the target so minimal of muscular activity is needed to center the sights on the target, this is referred to as **the natural point of aim**.

Several classic shooting positions have evolved over the years. You have already learned the bench-rest position and used it many times. It is the most stable of all shooting positions. We used it to learn basics because it gives shooters a high level of support and success.

The **standing position** is the most challenging. It involves fewer points of support for the rifle, more muscle activity and less stability than all the others. Two basic forms of the standing position differ only in the amount of support for the non-dominant arm. The **armrest standing position** is used for all types of target shooting. The **off-hand** or **free-arm standing position** was formerly used in light rifle shooting. It is still used by many field shooters when a more stable position is not possible.

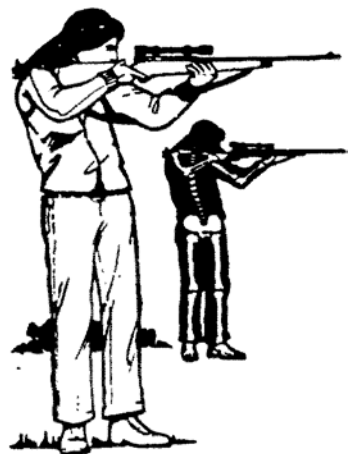



The **kneeling position** adds support and provides greater stability than either of the classic standing positions. Kneeling positions are used in smallbore position shooting and in field shooting.

The sitting position is more stable than the kneeling position. Two forms are most commonly seen, **cross-legged** or **closed sitting positions** and an **open- legged sitting position**. Both forms give excellent shooting results. In four- position rifle shooting, the rules define legal sitting positions. Field shooters also use this position.



The **prone position** is the most stable of the classic shooting positions. It is used in numerous types of shooting, both on the range and in the field.

All of these positions may be used with additional support by field shooters. Portable supports like shooting sticks or rifle mounted bipods or any available structural support like trees, posts, rocks or logs can add support for better shot placement.

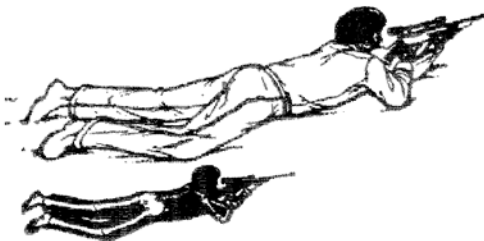

[*Instructor note:* The best and most successful learning sequence for young people who can handle all of these positions moves from the bench- rest position to standing. After the basics of the standing position are learned, the shooter can proceed to kneeling, sitting and prone – *in that order!*]

Teach all of the positions, even if your event or the one you think they are interested in learning does not involve all of them. Rifle shooters tend to do more than one thing, and the positions will find use in their shooting. We begin with the most difficult and unstable of the positions and move toward the most stable one. That aids learning in several ways. The leap from the bench to standing is tremendous. Scores plummet, but the shooter understands the potential accuracy of the rifle. As a result, they know that work must be done to improve their standing position scores. Muscle tremor and fatigue enter the picture with the progression through the positions stability and achievement increase. That builds confidence and reinforces the need for concentration on the standing position or its poor utility for field shooting. The young person is also challenged to continue practicing for better scores.

You will note that *breath control* has not been mentioned thus far. Nearly every shooter will stop breathing naturally during the sighting and shooting sequence. Mentioning breath control or advising any of the outmoded ways of proper breath control causes more problems than it cures. Comment on it only if a shooter is having problems, then note that the best shooters

merely stop breathing for a brief time (about three to five seconds) after a shallow inhalation.]

Learning the Standing Positions

The most commonly used standing position is the arm-rest standing position. The shooter stands with the feet about shoulder-width apart and the toes at nearly a right angle to the target. The weight is equally distributed, and the shoulders are in line with the target. The head and body are erect. As the rifle is mounted, the body bends back slightly to counter the mass of the rifle and keep the center of mass over the spot between the feet. The upper part of the non-dominant arm lies along the rib cage and is supported by it. For shooters who are able to do so, the elbow rests on or inside the flare of the hip. Try getting into position without the rifle. The butt of the rifle is placed high in the shoulder pocket, so the sights are at eye level without moving the head. The dominant hand grasps the rifle grip with the trigger finger along the trigger guard. The non-dominant hand supports the rifle's forend the hand supporting the stock may be open, held flat under the forend, clenched into a fist with the rifle resting on the first digits of the fingers or pinched together with the forend resting on the finger tips or the thumb and finger tips. All of these positions are acceptable. Try them and see which one fits you best.

Fatigue is a significant factor in shooting from the standing position. Shooters in position matches rest the rifle on rifle stands between shots. Many coaches and range officers consider the rifle stand an important safety device as well. It keeps the rifle pointed down range while allowing the shooter an opportunity to rest between shots. Rifle stands need not be elaborate or expensive. They should hold the rifle slightly below shoulder height, permitting the shooter to load the rifle and begin aligning the sights before the rifle is lifted from the stand and positioned for firing the next shot.

The body should be moved until the rifle rests on the target naturally. This "natural point of aim" is basically having your rifle aligned with your target to minimize the effects of body movement. To achieve natural point of aim, the shooter gets into position with eyes closed. When the eyes are opened, if the sights are not pointing at the target the shooter adjusts his/her stance. Vertical adjustments can be made by changing target height, moving the supporting hand forward or backward on the forend, changing the body posture slightly or applying muscle power. The last option is the least desirable, since it involves muscular movement and joint instability. Horizontal adjustments are made by moving the feet until the rifle rests on the target naturally. Having the natural point of aim on the target reduces the wobble area to a minimum and increases both consistency and accuracy.

Let's dry fire several shots. [Use the expanded range commands and walk the shooters through several shots. Reverse roles and repeat the dry-firing sequence. Repeat several times if needed.]

Now let's try a series of five shots. Pick a single bull on the target, take your time and shoot at the same point of aim for each shot. [Use the expanded range commands for the first shot, then allow the shooters to fire the rest of the shots on their own. Reverse roles after five rounds and repeat the sequence several times if desired. Change targets and analyze the groups between shooting sessions, forcing the shooters to rest. Left on their own, the shooters will tend to shoot too much, too quickly and without adequate rest. That results in learning bad habits. Prevention is easier than a cure.]

Other Standing Positions

The free-arm standing position or off-hand position is less stable than the arm-rest standing position. The only difference is the position in the posture of the arm supporting the forend. The arm-rest position supports the arm with the side of the body. The free-arm position has the arm extended enough for the upper arm to be held away from the body.

The supported-standing position makes use of any available support to add stability to the arm supporting the forend. Rigid objects make the best supports. If the support is made of hard material, the non-dominant hand should form a cushion between the support and the rifle stock.

Supported standing positions are not used in formal target shooting, but they are extensively used by hunters. The purpose of the rifle in hunting is to achieve a quick, clean kill. Any aid to accurate shot placement, like the use of support for shots taken from the standing position, shows respect for the game animal and sound hunting ethics.

Let's shoot another group on one bull of the target using a supported- standing position and compare the results with those fired from the arm- rest standing position. [Use the expanded range commands and encourage careful shooting. Reverse roles and repeat with the other shooters. Compare the group size and placement for those shot without support and those with it. Discuss the reasons and usefulness of the supported position.]

Summary

In this session we introduced the basic shooting positions and learned how to use the standing position. We shot groups using the formal standing position and a supported one. We discussed the off-hand or free-arm standing position. We stressed the importance of aligning the body with the target so the target is on the rifle's natural point of aim. Next time we will introduce the kneeling position.

Summary Activities

1. Compare the groups fired from the two starting positions and discuss the reasons for the differences.
2. Analyze the shot placement on a series of standing targets relative to alignment with the natural point of aim, looking for lateral stringing of the shots.
3. Diagram the skeletal support of shooter in standing position.
4. Allow shooters to fire a ten-shot match from the standing position and record the results in their shooting journals.

Sharing and Exhibit Ideas

1. Make a poster showing a proper standing position. Illustrate skeletal support and proper rifle positioning.
2. Demonstrate one or more of the standing positions.
3. Record what you learned today and the scores in your shooting journal. Exhibit the journal at a suitable event.
4. Record your progress in shooting from the standing position on a graph, taking the results from your shooting journal. Discuss the changes you made or the reasons for the progress.
5. Study a shooting match that uses a standing position. Share the content and rules of the match with your shooting group or another interested group.

Kneeling Position

John Kvasnicka, Ronald A. Howard Jr. and William F. Stevens*

Objectives

Participating youth and adults will:

1. Understand and practice the kneeling rifle position.
2. Practice the supported kneeling position.
3. Practice safe range and shooting procedures.
4. Apply and practice skeletal support and finding a natural point of aim.
5. Have fun while learning.

Roles for Teen and Junior Leaders

- Demonstrate the kneeling position.
- Act as assistant range officers.
- Assist shooters with their positions.
- Score targets.
- Assist with making kneeling rolls

Parental Involvement

- *See* Roles for Teen and Junior Leaders above.
- Assist shooters needing special attention.
- Provide materials for kneeling rolls.
- Supervise one or more firing points.
- Arrange for or provide transportation.
- Arrange for or provide refreshments.

* Executive Director, Minnesota Deer Hunters Association; 4-H and Youth Development Specialist, Texas Agricultural Extension Service; and Conservation Affairs Manager for Federal Cartridge Company, Anoka, MN.

Best Time to Teach

Any time of year, but after teaching the standing position and before teaching sitting or prone positions

Best Location

Any safe shooting range

Time Required

Approximately 1 hour

Materials/Equipment

- rifles
- ammunition
- targets
- tape, clips or other target hanging materials
- eye and ear protection
- shooting mat
- kneeling roll
- chairs or benches
- adequate backstop
- open bolt indicators

References

- NRA Junior Rifle Shooting.*
G. Anderson. National Rifle Association, Washington, DC. 1983.
- The NRA Junior Rifle Handbook.*
G. Anderson. National Rifle Association, Washington, DC. 1983.
- The Basics of Rifle Shooting.*
H.W. Sheets. National Rifle Association, Washington, DC. 1987.
- Student Handbook for Junior Position Air Rifle.* Lt. Col. L. Lujan, ed. National Guard Marksmanship Center, Camp Robinson, North Little Rock, AR.

Teaching Outline

Presentation

I. Review

- A. Safety and range operation
- B. Skeletal support
- C. Natural point of aim and aligning body with target
- D. Standing positions
 1. Arm-rest standing
 2. Free-arm standing
 3. Supported-standing

II. Review the arm-rest standing position

- A. Dry Fire
- B. Live fire
- C. Change targets

III. Learning the kneeling position

- A. Lower body position
 1. Dominant side
 - a lower leg tucked under body
 - b kneeling roll under front of ankle, supporting foot
 - foot position
 - heel raised, sitting on heel
 - Dry fire foot tucked sideways, sitting on instep
 - toes pointed, sitting on heel
 2. Non-dominant lower leg vertical
 3. Sitting on dominant-side foot (hips clear of floor or mat)
- B. Upper body position
 1. Non-dominant elbow on upright knee
 2. Head erect and relaxed
 3. Body inclined forward and relaxed
- C. Rifle position
 1. Butt high in shoulder pocket
 2. Sights at eye level
 3. Dominant hand grasping grip
 4. Non-dominant hand supporting forend
- D. Alignment with the target
 1. Natural point of aim on target

Application

Use questions to **STIMULATE** a review. **STRESS** skeletal support, using natural point of aim and aligning body with target.

Briefly **REVIEW** standing position. Have shooters **DRY FIRE** several shots, then **FIRE** ten record shots on standard target.

DEMONSTRATE and have shooters **TRY** kneeling position without equipment. **STRESS** using a comfortable position for dominant-side foot.

DEMONSTRATE use of a kneeling roll. **ADJUST** positions as needed.

STRESS having relaxed body. **COMMENT** on rule that buttocks cannot touch mat or ground.

DEMONSTRATE elbow positions and **STRESS** skeletal support. **EMPHASIZE** relaxed and comfortable body and head position.

DEMONSTRATE bringing rifle to eye by adjusting the butt location or adjusting butt plate. **ADDRESS** use of sling or hand stop if they are available. Have shooters **PRACTICE** adjusting and using them with safe rifles on range.

EMPHASIZE using natural point of aim for best results.

2. Vertical adjustment
 - a change target height
 - b lower rifle by moving supporting hand forward
 - c raise rifle by moving supporting hand back
 3. Horizontal adjustment
 - a rotate body left or right
 - b pivot on dominant foot or ankle
- E. Dry fire from the kneeling position
- F. Live fire from the kneeling position
1. Shoot five shots at one bull
 2. Concentrate on form and group
 3. Reverse roles and repeat

IV. Supported kneeling position

- A. Body position as above
- B. Support forend and hand
 1. Cross-sticks
 2. Chair back
 3. Other support
- C. Live fire
 1. Select one bull
 2. Fire five shots
 3. Concentrate on group
- D. Compare supported and classic kneeling groups

V. Summary

- A. Review of position shooting
- B. Review of standing positions
- C. Kneeling position
 1. Classic kneeling position
 2. Supported kneeling position
- D. Sitting position next time

DEMONSTRATE vertical and horizontal adjustments in rifle position.

Have shooters **DRY FIRE** several rounds, then **LIVE FIRE** a five-shot group on a selected bull. **REVERSE** roles and repeat process.

DEMONSTRATE supported kneeling position and have shooters **FIRE** another group on second bull.

COMPARE size of two kneeling groups and **DISCUSS** reasons for the differences. Have shooters **FIRE** a ten-shot kneeling match if time permits.

Use **QUESTIONS** to stimulate review of kneeling position.

SCORE targets, **DISCUSS** scores and **ENTER** day's shoot in shooting journal.

Lesson Narrative

Position rifle shooting involves the same personal and shooting safety procedures we have been practicing up to this time. Two major principles govern all position shooting. First, the support for the rifle must be supplied as much as possible by the bones, not the muscles. Second, the shooter will perform best when the body is relaxed and the natural point of aim for the rifle is on the target. In the last session we learned about standing positions and fired from the classic target shooter's standing position and a supported-standing position. We are going to shoot a ten-shot match from the standing position to review.

Reviewing the Standing Position

[Instructor note: Use the standard range commands to control the line.] Before we do any live firing, dry fire several times to prepare yourself. Now fire a ten-shot match. Shoot only one shot at each scoring bull. If you need to fire some sighters, use the two bulls in the sighting ring. (Allow all shooters to fire a ten-shot series, keeping things moving, but not hurrying the shooters.) Now retrieve your targets and put fresh ones on the hangers.

Learning the Kneeling Position

The kneeling position gives more support than the standing position. Watch carefully as we demonstrate. The dominant-side leg is tucked under the body with a kneeling roll tucked under the ankle or foot. Three foot positions are acceptable. The foot may be supported by the toes with the heel raised, allowed to lie on its outer side or stretched out with the top surface on the ground or mat (supinated). The shooter may sit on the foot or heel as long as the buttocks do not touch the mat or ground. The non-dominant leg is held with the lower leg vertical as a support for the non-dominant arm.

The non-dominant elbow is placed on or over the upright knee, forming a fairly solid brace for the supporting arm. The head is erect and relaxed. The body inclines forward slightly, supported on the elbow and knee. The body should be relaxed.

The rifle is positioned rather high in the shoulder pocket, bringing the rifle into alignment with the shooter's eye. On rifles with adjustable butt plates, the butt plate can be lowered to fit the shoulder pocket while the comb is raised to position the sights in line with the eye. The dominant hand grasps the rifle's grip with the trigger finger along the trigger guard. The non-dominant hand supports the forend. The hand may be braced against a hand stop and the arm may be supported by a sling.

The natural point of aim must be on the target if the best accuracy is to be achieved. Aligning the body to the target so the rifle points naturally to it is essential. Vertical adjustments in the natural point of aim can be achieved either by moving the target to the existing point of aim or by moving the position as the hand on the forend. Moving the hand forward

(toward the muzzle) lowers the rifle. Moving it back (toward the receiver) raises the rifle. Horizontal adjustments are made by pivoting the body on the dominant foot or the kneeling roll and moving the upright (non- dominant) leg into alignment with the target. Try getting into a kneeling position without a rifle. Let the teen leaders and other range assistants help you.

Shooting from the Kneeling Position

[Use the standard range and shooting procedures to control the line during this shooting session.]

Now, let's apply what we have learned about the kneeling position on the range. Dry fire several shots before shooting a five-shot group on a selected bull. Check to make sure that the rifle is lining up with the target naturally. Concentrate on your shooting form and shoot a group using a consistent sight picture.

Using a Supported-kneeling Position

Many field shooters find an application for a supported-kneeling position. Shoot another group on a different bull using the position being demonstrated. Any support for the forend and hand can strengthen the kneeling position. Shooters often used cross sticks or other available support. In the range environment, a chair back makes a convenient rest. Remember to cushion the forend with the hand during the firing. Compare the group you shot in the classic kneeling position with the one fired from the supported position. How do the two groups compare? Why might a field shot prefer to have the additional support? [If time permits, have the shooters fire a ten-shot kneeling match as a wrap-up activity.]

Summary

In this session, we reviewed the fundamentals of position shooting from the standing position and learned to use the kneeling position. We also compared a supported-kneeling position with the classic, target-shooting kneeling position. In our next session we will explore the sitting position.

Summary Activities

1. Have all shooters fire a ten-shot match from the kneeling position. Score the targets and enter the scores in journal.
2. Discuss the difference between the standing and kneeling scores and the reasons for that difference. Focus on differences in stability of the positions and the number of support points.
3. Have each shooter try using different positions for the dominant foot to determine which of them is most comfortable.
4. If it has not been done already, demonstrate how to use stock adjustments to aid in proper shooting form. Include the use of the sling and hand stop.

Sharing and Exhibit Ideas

1. Make a poster showing proper kneeling positions. Include an outline of skeletal support and rifle positioning.
2. Demonstrate the kneeling position, showing the variety of foot positions possible. Discuss adjustments for placing the natural point of aim on the target.
3. Record your scores and the new things learned in this session in your shooting journal. Exhibit the journal in a suitable event.
4. Record your progress in the kneeling position on a graph, taking the results from entries in your shooting journal. Discuss the changes you have made and the reasons for them.
5. Study a shooting game that uses the kneeling position. Share the game and its rules with other shooters in your group or with other interested persons.
6. Share what you have learned about rifle shooting positions with an interested adult.

Sitting Position

John Kvasnicka, Ronald A. Howard Jr. and William F. Stevens*

Objectives

Participating youth and adults will:

1. Review and practice the standing and kneeling positions.
2. Understand and practice the sitting rifle position.
3. Practice a supported sitting position.
4. Practice safe range and shooting procedures.
5. Apply and practice skeletal support and finding a natural point of aim.
6. Have fun while learning.

Roles for Teen and Junior Leaders

- Demonstrate the sitting position.
- Act as assistant range officers.
- Assist shooters with their positions.
- Score targets.

Parental Involvement

- See Roles for Teen and Junior Leaders above.
- Assist shooters needing special attention.
- Supervise one or more firing points.
- Arrange for or provide transportation.
- Arrange for or provide refreshments.

Best Time to Teach

Any time of year, but after teaching the standing and kneeling positions and before teaching the prone position

Best Location

Any safe shooting range

Time Required

About 1 hour

Materials/Equipment

- rifles
- ammunition
- targets
- tape, clips or other target hanging materials
- eye and ear protection
- shooting mats
- open bolt indicators

References

NRA Junior Rifle Shooting.
G. Anderson. National Rifle Association. Washington, DC.1983.

The NRA Junior Rifle Handbook.
G. Anderson. National Rifle Association, Washington, DC. 1983.

The Basics of Rifle Shooting.
H.W. Sheets. National Rifle Association, Washington, DC.1987.

Student Handbook for Junior Position Air Rifle. Lt. Col. L. Lujan, ed. National Guard Marksmanship Center, Camp Robinson, North Little Rock, AR.

* Executive Director, Minnesota Deer Hunters Association; 4-H and Youth Development Specialist, Texas Agricultural Extension Service; and Conservation Affairs Manager for Federal Cartridge Company, Anoka, MN.

TEACHING OUTLINE

Presentation

Application

I. Review

- A. Safety and range operation
- B. Skeletal support
- C. Natural point of aim
- D. Standing position
- E. Kneeling position
- F. Supported standing and kneeling positions

Use questions to help shooters **REVIEW** the main points of safety and position shooting covered to date. **STRESS** skeletal support and natural point of aim.

II. Practice with the standing position

- A. Arm-rest standing position
- B. Dry fire several times
- C. Live fire ten rounds

Have shooters **FIRE** a ten-shot match from standing position.
USE standard range procedures.

III. Practice with the kneeling position

- A. Classic kneeling position
- B. Dry fire several times
- C. Live fire ten rounds

Have shooter **FIRE** a ten-shot match from the kneeling position.
USE standard range procedures.

IV. Learning the sitting position

- A. Body position
 - 1. Sitting on mat or ground
 - 2. Body inclined forward at waist
 - 3. Head relaxed (slightly forward)
 - 4. Extended open position
 - a nearly square to target
 - b knees fairly high
 - c feet braced about shoulder width apart
 - d elbows inside or in front of knees
 - 5. Extended crossed ankles
 - a body facing about 30 degrees to the dominant side of target
 - b legs crossed at ankles
 - c elbows in inside hollows of knees
 - 6. Crossed-leg position
 - a body oriented 45 to 60 degrees to dominant side of target

DISCUSS and **DEMONSTRATE** sitting positions.

Have each shooter **EXPERIMENT** with these positions without equipment to determine which one fits their build and size.

STRESS nearly equal and excellent support in these positions.

- b. lower legs crossed
 - non-dominant leg over dominant one
 - sides of feet tucked under opposite leg
 - elbows resting in hollows inside knees

B. Gun position

1. Butt of rifle in shoulder pocket
2. Sights at eye level
3. Non-dominant hand supports forend
4. Dominant hand on grip

C. Aligning the body to the target

1. Vertical adjustments
 - a. alter target location
 - b. moving the forend arm
 - forward to lower rifle
 - back to raise rifle
 - c. moving feet
 - -forward or toward each other to lower rifle
 - back or away from each other to raise rifle
2. Horizontal adjustments
 - a. rotate position in desired direction

V. Shooting from the sitting position

- A. Obtain a proper sitting position
- B. Dry fire several times
- C. Live fire five shots at a single bull
- D. Reverse roles and repeat

VI. Summary

- A. Position shooting
 1. Skeletal support
 2. Natural point of aim
- B. Review of standing and kneeling positions
- C. Sitting position
- D. Prone position next time

DEMONSTRATE alterations in adjustment or use of sling during this phase. **NOTE** that head will be slightly forward.

DEMONSTRATE both vertical and horizontal position adjustments.

USE standard range and shooting procedures to walk shooters through **DRY FIRING** and **LIVE FIRING** for a group.

If time permits, have each shooter **FIRE** a ten-shot match from sitting position.

REVIEW positions used so far. **COMMENT** on increasing level of support and changes in scores or group sizes.

Lesson Narrative

We have become very familiar with personal and shooting safety on the range, and we have learned to apply the basic principles of position shooting. We make every effort to have the target location coincide with the natural point of aim for the rifle. We also strive to have the rifle supported primarily by the bones with as little muscle involvement as possible. We have fired from the standing and kneeling positions, both with and without support and noted the differences in our group size and scores. We also shot several short matches while reviewing the basics of those positions. During this session, we will explore the sitting position and find one that is most effective for us.

Practicing the Standing and Kneeling Positions

[Use standard range commands and procedures to control the line.] Before doing any live firing, dry fire several times to help your *mind* prepare for a short match. Now fire a ten-shot match from the standing position. Remember to shoot only once at each bull. If you need to fire any sighters, use the two bulls inside the sighting ring. [Allow the shooters to fire a ten-shot series. Keep things moving, but do not rush them as they shoot.]

Assist your partner as he or she fires their record shots standing. Retrieve those targets and replace them with fresh ones. Fire another ten-shot match, this time from the kneeling position. When you are finished, make your rifles safe and ground them.

Learning the Sitting Position

The sitting position is used in four-position shooting and in field shooting. It has abundant support for the rifle and provides a stable platform for accurate shooting. The shooter sits on the ground or the shooting mat, using the legs as supports for the elbows. Several acceptable styles of sitting position are used. We will demonstrate each one and allow you to try them without equipment. Then you can apply the one you prefer on the range.

All sitting positions share some common elements. The shooter is sitting down, firmly planted on the ground or mat. The body is inclined forward from the *waist*, relaxed and resting on the elbows. The head is as erect as possible, leaning forward slightly to avoid strain on the neck. The elbows are braced at the knees.

In the extended, open sitting position, the shooter sits nearly square to the target. The knees are fairly high, and the feet are firmly planted a bit more than shoulder width apart. The elbows are usually set inside the knees or slightly ahead of the knees. Note that placing the point of the elbow on the point of the knee is quite unstable, almost like trying to put two balls atop each other. In the extended, crossed-ankle sitting position, the shooter sits facing about 30 degrees to the dominant side of the target. The legs are extended forward with the ankles crossed. The elbows rest on the insides of the knees.

In the closed sitting position, the shooter sits facing slightly more to the dominant side of the target, perhaps 45 to 60 degrees. The non-dominant side leg is crossed over the dominant-side leg and pulled in rather close to the body. The feet are tucked up under the opposite legs, supporting them with the sides of the foot. As in the other positions, the elbows rest in the hollows inside the knees.

The butt of the rifle is settled in the shoulder pocket, and the sights are level with the eye. The non-dominant hand supports the forend of the rifle, perhaps with the aid of a sling and hand stop. The shooting hand grasps the rifle grip with the trigger finger lying along the trigger guard.

Vertical adjustments in the point of aim are made by changing the target height, the location of the hand on the forend or the position of the feet. Moving the hand forward on the forend lowers the rifle. Moving it back toward the receiver raises it. Similarly, extending the legs (feet) or moving them further apart lowers the rifle. Drawing the feet toward the body or moving them toward each other raises the rifle. Horizontal adjustments are accomplished by pivoting the entire stance from the base.

Try these positions without equipment to see which suits your build and size the best. All of them are stable and completely acceptable sitting positions. Raise your hand if you need some help or have a question.

Shooting from the Sitting Position

[Use standard range procedures to control the range during this firing sequence.] Let's move to the range and try this new position by firing a group. First, get into the sitting position you have selected. Orient yourself to the target, and dry fire several shots to get the feel of the position. Select a single bull and fire five shots trying to shoot a nice, tight group. Change roles with your partner and repeat the process. [After the targets are retrieved, pause while the groups are discussed. If time permits, have each shooter fire a ten-shot match from the sitting position, score the targets and evaluate the results.]

Summary

In this session we have reviewed the principles of using the natural point of aim and using skeletal support for solid shooting positions. We have fired short, practice rounds from the standing and kneeling positions; and we have developed a sitting position. In the next session, we will be exploring the most stable of the shooting positions -prone.

Summary Activities

1. Have each shooter fire a ten-shot match sitting. Score the targets fired from the three positions and evaluate the scores. Record all scores in the shooting journal.
2. Discuss the differences in the scores or groups fired from the three positions. Focus on the number of support points for the position and their stability.
3. Have each shooter try each of the sitting positions to see which one is most comfortable and consistent for them.
4. Demonstrate the use of the sling, other accessories and stock adjustments and their impact on attaining a proper position.

Sharing and Exhibit Ideas

1. Make a poster of the sitting positions. Include an outline of the bones supporting the position and the proper position of the rifle.
2. Demonstrate the various sitting positions for another interested person, showing how to alter the natural point of aim to compensate for different target locations.
3. Record your scores and the new things learned in this session in your shooting journal. Exhibit the journal at a suitable event.
4. Record your progress in the sitting position on a graph. Extract the data and your observations from your shooting journal. Discuss the changes you have made and the reasons for them.
5. Share what you have learned about rifle shooting positions with an interested adult.

Prone Position

John Kvasnicka, Ronald A. Howard, Jr. and William F. Stevens*

Objectives

Participating youth and adults will:

1. Understand and practice the prone rifle position.
2. Practice the standing, kneeling and sitting positions.
3. Practice safe range and shooting procedures.
4. Apply and practice skeletal support and finding a natural point of aim.
5. Have fun while learning.

Roles for Teen and Junior Leaders

- Demonstrate the prone position.
- Review the standing, kneeling and sitting positions.
- Act as assistant range officers.
- Assist shooters with their positions.
- Score targets.

Parental Involvement

- See Roles for Teen and Junior Leaders above.
- Assist shooters needing special attention.
- Provide materials for kneeling rolls, shooting mats or other accessories.
- Supervise one or more firing points.
- Arrange for or provide transportation.
- Arrange for or provide refreshments.

Best Time to Teach

Any time of year, after teaching the other basic rifle shooting positions

Best Location

Any safe shooting range

Time Required

About 1 to 2 hours

Materials/Equipment

- rifles
- sling
- ammunition
- targets
- tape, clips or other target hanging materials
- eye and ear protection
- kneeling roll
- shooting mat
- open bolt indicators

References

NRA Junior Rifle Shooting.
A. Anderson. National Rifle Association, Washington, DC. 1983.
The NRA Junior Rifle Handbook.
G. Anderson. National Rifle Association, Washington, DC. 1983.
The Basics of Rifle Shooting.
H.W. Sheets. National Rifle Association, Washington, DC. 1987.
Student Handbook for Junior Position Air Rifle. Lt. Col. L. Lujan, ed. National Guard Marksmanship Center, Camp Robinson, North Little Rock, AR.

* Executive Director, Minnesota Deer Hunters Association; 4.H and Youth Development Specialist, Texas Agricultural Extension Service; and Conservation Affairs Manager for Federal Cartridge Company, Anoka, MN.

TEACHING OUTLINE

Presentation

I. Review

- A. Safety and range procedures
- B. Skeletal support and natural point of aim
- C. Position shooting
 1. Standing positions
 2. Kneeling positions
 3. Sitting positions
- D. Prone

II. Practice shooting

- A. Standing position
 1. Arm-rest standing position
 2. Dry fire
 3. Live fire ten rounds
- B. Kneeling position
 1. Preferred foot position
 2. Dry fire
 3. Live fire ten rounds
- C. Sitting position
 1. Preferred sitting position
 - a extended, open
 - b extended, crossed ankles
 - c closed, crossed legs
 2. Dry fire
 3. Live fire ten rounds

III. Learning the prone position

- A. Proper body position
 1. Body prone, belly down on mat
 2. Line through body pointing slightly to dominant side of target
 3. Non-dominant elbow in front of body
 4. Dominant-side knee slightly flexed
 5. Head relaxed and erect
 6. Weight shifted slightly to non-dominant side
- B. Butt of rifle in shoulder pocket
 1. Sights at eye level
 2. Non-dominant hand supports forend of rifle
 - a upper arm and hand supported by sling
 - b use of hand stop or swivel
 - c forearm at minimum of 30 degrees to mat or ground

Application

Use questions to **REVIEW** fundamentals of personal and range safety and fundamentals of rifle shooting.

INTRODUCE prone position as most stable shooting position.

Using standard range and shooting procedures have each shooter **DRY FIRE** several shots in each position, then **LIVE FIRE** a ten-shot match in each one. **REVERSE** roles and repeat procedure with other member of coach-pupil pair.

SCORE fired targets.

DEMONSTRATE proper prone position while **DISCUSSING** elements of sound prone shooting position.

SHOW that flexing the knee reduces heart tremor and increases comfort for some shooters.

DEMONSTRATE adjusting butt plate for proper eye alignment and sling or hand stop position to provide more support.

MENTION minimum forearm angle is a rule for position shooting.

3. Dominant hand on rifle grip
4. Dominant elbow on mat
- C. Aligning rifle with the target
 1. Target at natural point of aim
 2. Vertical adjustments
 - a Alter target height
 - b Move non-dominant hand
 - Forward on forend lowers rifle (30 degrees to mat is minimum)
 - Back toward receiver raises rifle
 - Adjust sling and hand stop if present
 3. Horizontal adjustments
 - a pivot on non-dominant elbow
 - b move body left or right
 - c adjust to natural point of aim
- D. Dry fire several times
 1. Use standard range commands and procedures
 2. Check natural point of aim
 3. Adjust position as needed
- E. Live fire
 1. Select a single bull
 2. Fire a five-shot group
- F. Supported-prone position
 1. Support rifle
 - a rifle rest
 - b post
 - c sandbags
 2. Select another bull
 3. Fire a five-shot group
- G. Reverse roles and repeat
- H. Replace targets and fire a ten- shot prone match

IV. Summary

- A. Position rifle shooting
 1. Placing target on natural point of aim
 2. Relaxed neck and body
 3. Obtaining maximum bone support - minimum muscle action
 4. Sights brought to eye level
 5. Support for field shooting
- B. Standing position
 1. Rifle over center of mass
 2. Arm resting on side

Have each shooter **PRACTICE** this position without a rifle.

Have shooters move to firing line and **ASSUME** a proper prone position. **ASSIST** shooters with position adjustments to put rifle on target using natural point of aim.

STRESS use of sling for additional support in prone position.

STRESS pivoting body on forward elbow and **NOT** muscling rifle into position.

Use standard range and shooting procedures to **DRY FIRE** and **LIVE FIRE** a five-shot group on a single bull.

Have shooters **ADD** support to their prone position and **LIVE FIRE** a second five-shot group at another bull. **COMPARE** group sizes and **DIS- CUSS** reasons.

FIRE a ten-shot prone match to summarize activity.

TRESS core concepts of position rifle shooting.

Have shooters **REVIEW** each of positions they have learned and **DISCUSS** key points in each one. **STRESS** relationship between amount of support and ease of hitting target precisely.

- C. Kneeling position
 - 1. Rifle on upright leg and forearm
 - 2. Lower body sitting on foot
- D. Sitting position
 - 1. Body sitting on ground
 - 2. Forearms supported on knees
 - 3. Knees braced
- E. Prone position
 - 1. Most stable
 - 2. Body lying on mat or ground
 - 3. Elbows braced on mat
 - 4. Rifle supported by forearms and accessories
- F. Perfect practice makes perfect

REVIEW scores shot in each match of day.
ASSIST shooters in making journal entries and
START a practice schedule for any shooters
wanting to participate in position rifle shooting.

Lesson Narrative

We will continue to use the personal and shooting safety procedures as we have throughout these sessions on rifle shooting. Supporting the rifle with the bones while minimizing the use of muscle power is essential to good rifle shooting. Using a proper position and moving the body to place the target at the rifle's natural point of aim enhance the ability to shoot well. Aside from the muscles that must be used, the body should be comfortable and relaxed when shooting.

We have learned three positions so far. We started with the standing position, learning three varieties: arm-rest, free-arm and supported-standing positions. We have practiced a proper standing position each time. The kneeling position also involved three variations. The dominant foot could be placed in three attitudes, with the shooter sitting on the foot. Additional support could be added to the kneeling position by field shooters when conditions were appropriate. Then we added the sitting position. It provided greater support and stability, and we tried several forms to find the one most consistent and comfortable for us. Today we will be learning the most stable of rifle position without additional support - the prone position.

Review and Practice Shooting

(Instructor note: All shooting in this session should use the standard range commands and shooting procedures. If time does not permit shooting matches in each position, have shooters fire three to five shots from each of the positions learned earlier. This constant reinforcement is a strong aid to learning.)

Before we begin learning the prone position, let's review the other positions we have learned. With the assistance of your coach and the range assistants, get into your standing position. Dry fire several times to refresh your skills, then shoot ten record shots. Remember to shoot only once at each bull. You may fire as many sighter shots as needed, but be sure to keep them on the sighting bulls.

Once you have completed the standing stage, change targets and repeat the sequence (dry firing and live match) with the kneeling and sitting positions. Pay careful attention to your shooting form to build stable shooting positions. After the shooters on the first relay have fired their standing, kneeling and sitting scores, change roles and have the other members of the coach-pupil teams fire the same course.

Learning the Prone Position

The prone position is the most stable of the unsupported rifle shooting positions. The body is supported for almost its entire length on the ground. The elbows are braced on the mat or ground, and the rifle is supported by both elbows and the shoulder. To develop a prone position, the shooter lies down on the shooting mat facing slightly to the dominant side of the target. The non-dominant elbow is in front of the shooter. Most shooters find that flexing the dominant knee slightly gives them a more stable and comfortable position with less tremor from their heartbeat. Flexing the knee will force the weight to

shift slightly to the non-dominant side. The feet may be supported on the tips of the toes, turned in or turned out at the shooter's discretion. Avoid the temptation to cross the feet with the legs straight. Doing so tends to invite a narrow, less stable position and tremors caused by moving the feet. The head should be as erect as possible without causing muscle strain. The neck should feel relaxed. Try this position without a rifle, and experiment with leg and foot positions to find one that is comfortable and stable for you.

The butt of the rifle should be firmly planted in the shoulder pocket with the sights at eye level. The non-dominant hand should support the forend of the rifle. On rifles equipped with slings and hand stops, the sling should be carefully adjusted to provide additional support for the forward arm. The hand should be firmly pressed against the hand stop and held in place by the sling. If this method is to be used, a shooting glove is almost essential for shooter comfort. The rules for position shooting require the shooter's forearm to maintain an angle of 30 degrees or more from the mat or ground. Braced in this position, the rifle should return naturally to alignment with the shooter's eye after any disturbance of the rifle's position. The dominant or shooting hand grasps the rifle's grip and provides additional support from the elbow being braced against the mat or ground.

Aligning the Rifle to the Target

Moving the body to have the rifle point to the target naturally is the key to good prone shooting. Vertical adjustments can be made by altering the target height if necessary. Minor adjustments in vertical position can be made by altering the location of the forward hand on the forend. Moving the hand forward lowers the muzzle while drawing it back raises the muzzle. Any alterations in hand position should be done along with adjustments to the hand stop and sling if they are being used.

Horizontal positioning is accomplished by pivoting the body. The forward elbow should be the pivot point for the body. All adjustments should be made involving the entire torso and lower body, allowing the body to be relaxed in the shooting position. Test the position to see that it is naturally aligned with the target, and re-adjust the position until it is right. Dry fire several times to check your position, then fire a five-shot group at one bull on the target. Once you have fired that group, add additional support (a post, rifle rest or sandbags) and fire a second group at a different bull. Then trade off with your partner and help him or her through the same firing sequence. Compare the supported and non-supported groups. Do they differ as much as the ones fired from the other positions? Why do you think that is the case? If time permits, each shooter should fire a ten-shot match from the prone position. Remember to shoot only once at each bull and to use the same position you have developed in the exercise where you shot for a group.

Summary

The core concepts of position rifle shooting have been developed. The target must be on the natural point of aim for the rifle, and that natural point of aim is adjusted by moving the body and the rifle as a unit. The neck and body are relaxed and comfortable. The rifle is supported as much as possible by the

skeleton or bones with muscle activity kept to a minimum. The sights are brought to eye level, using adjustments in the placement of the butt plate or by adjusting the butt plate. Although target shooters may not use additional support, field shooters use as much support as possible to ensure vital hits and quick, clean kills.

We have learned four basic rifle shooting positions. The standing position is the least stable and the most demanding of the shooter. The kneeling position adds support. Sitting offers still more, and the prone position is very stable. Each position is defined by specific rules in competitive events, but field shooters can adapt and blend them to fit their needs. In addition to the positions, we have gained more practice in scoring targets and shooting under match conditions. Remember that good shooting is not genetic. It is a skill that must be learned. Practice will not make perfect unless the shooter is practicing the positions properly and with strong concentration on each shot. Perfect practice makes perfect.

Summary Activities

1. Score all targets and discuss the scores fired at each stage with the shooters. Have them record their scores and anything they have learned in the session in their shooting journal.
2. Plan a position shooting program involving practice sessions and some sort of competitive event for those who are interested in competitive target shooting.
3. Compare the series of targets fired in any given position over the course of the instruction. Discuss the stability of the position and the size of the groups or the scores shot using them. Note progress in the scores and encourage continued practice.
4. Suggest additional rifle learning activities for those who wish to continue in rifle shooting. Consider other types of shooting for those who wish to explore them.

Sharing and Exhibit Ideas

1. Demonstrate a selected rifle position for an interested audience, pointing out the stability of the position and any rules related to it.
2. Research a rifle shooting game and share it with your shooting group or another interested group.
3. Attend a rifle match and share the experience with other shooters in your group.
4. Display your shooting journal at an appropriate event.
5. Conduct a series of experiments on the shooting positions by shooting several groups or sets of targets with each one under controlled conditions. Report your results and conclusions in an appropriate manner.
6. Share what you have learned about position rifle shooting with an interested adult or another youth audience.
7. Develop a series of posters on position shooting and shooting safety for a local shooting club.

Determining Eye Dominance

Ronald A Howard Jr. and James V. Peter, Jr. *

Eye Dominance

Most people have a dominant eye, just as they have a dominant hand or foot. When a person looks at an object with both eyes, the dominant eye aligns directly with the object unless an obstruction interferes with a clear line of sight. Under normal conditions, when a finger is pointed at an object, or two or more objects are aligned visually, the dominant eye determines the alignment. Just as some people are truly ambidextrous, a very small number of people have indeterminate eye dominance. The majority, however, have a dominant eye. In most cases eye dominance and hand dominance are on the same side, but many people are cross-dominant. That is, their handedness and eyedness are on opposite sides.

Humans have binocular vision – they get slightly different images from each eye and blend them in the brain to yield one image and a sense of depth or distance. With both eyes open, you have a wider field of vision with more peripheral vision and better motion detection. In shot, you simply see better when both eyes are used. Experience shows that shooting skills are learned more easily and often better developed when a shooter learns from the dominant eye side. Where eyedness and handedness are on the same side, new shooters easily use the dominant side. Cross-

dominant shooters have a greater challenge, but they do better when they learn to shoot with the dominant eye.

Some shooters, particularly those with successful experience in shooting with the non-dominant eye, are reluctant to switch. The switching process usually involves a brief period of reduced success and frustration, followed by improved skill levels beyond their original level. Some experienced shooters have learned to shoot one-eyed, closing the dominant eye or obstructing it with a shield, blinder, spot of tape or a small object on the lens of the shooting glasses. Others have learned to override their dominant eye through practiced concentration or to compensate in some other fashion. Fewer than 1 percent of all shooters must shoot one-eyed because of dominance switching. In most cases, the shooter learns to use both eyes and shoot from the dominant-eye side. Learning one-eyed or with the dominant eye obstructed or closed increases stress and fatigue, and reduces concentration and quickness. Results indicate reduced performance levels, increased frustration for the shooter and slower learning.

Learning to shoot well is a challenge. You need every advantage to meet that challenge effectively. Learning from the dominant-eye side is a major advantage.

How to Determine Eye Dominance

Four basic methods for determining eye dominance are described. Those that provide a check for “cheating” are more effective in an instructional setting. Regardless of the method selected, the exercise should be repeated several times. Instructors should remain alert for eye-dominance related problems with shooting performance.

Coach-pupil Method

Shooters should get into their coach-pupil pairs, standing several arm-lengths apart and facing each other squarely. The “pupil” should place one thumb over the other, then cross the fingers of the top hand over those of the bottom one. This leaves a small, triangular opening. Raise the hands, keeping both eyes open, and center the “coach’s” nose in the triangular opening. At this point the coach should note which eye is visible in the opening. Then the “pupil” should bring his or her hands slowly back to the face, keeping the “coach’s” nose in the opening. The hands should come to the dominant eye. Coaches must watch closely for wavering between the eyes, an indication of “cheating” or forcing the hands to a predetermined eye. The exercise should be repeated several times to confirm original results with both partners checking their eye dominance.

Option: Shooters could cup their hands together, leaving small openings between the bases of the little fingers and the thumbs. A card or a sheet of notebook paper with a small hole centered in it could also be used.

Distant-object Method

Use any of the methods of making an aiming device outlined above. Center a distant object in the opening. Make sure both eyes stay open and face the object squarely.

Finger-point Method

With a pointing method, a distant object or a partner is used. The finger is pointed naturally at the object with both eyes open and the face square to the object. The eyes are covered or closed alternately. When the dominant eye is closed, or covered the finger appears to jump away from the original location.

Tube Methods

Kaleidoscopes, toilet paper tubes and similar objects can be used with many young people to determine eye dominance. When the person is not aware of being tested for eye dominance, the tube will almost always be

brought to the dominant eye. This also occurs with spotting scopes, telescopes and similar tools where one-eyed viewing is needed.

Troubleshooting for Coaches and Instructors

Some shooters will bring the opening back to their own noses because they are looking at the paper or their hands rather than at the target. Those who use the finger-point method will see two fingers if they focus on their hand rather than on the target. If inconclusive results are obtained, try another method. Make note of that shooter, however, and watch for evidence of switching dominance in the act of shooting. Consistently missing to one side of the target usually indicates an eye-dominance related problem.

A Note of Caution

Vision problems can have a serious impact on shooting ability. Often, they go undetected by the shooter or those around them. Unless you are an ophthalmologist or optometrist, avoid “diagnosing” vision problems, but be aware of the types of problems a



shooter with vision problems may face. Discuss any potential problems you observe with the shooter and his or her parents. Like teachers who notice reading problems or other vision related difficulties, the shooting instructor may notice things that even the shooter misses.

Finally, be sure that all shooters are wearing adequate eye protection while they are on or near the firing line. Some people recommend the use of shooting glasses even for archers. Eyes are precious and vision is vital to shooting. Let's do our part in protecting them.

DOMINANT EYE

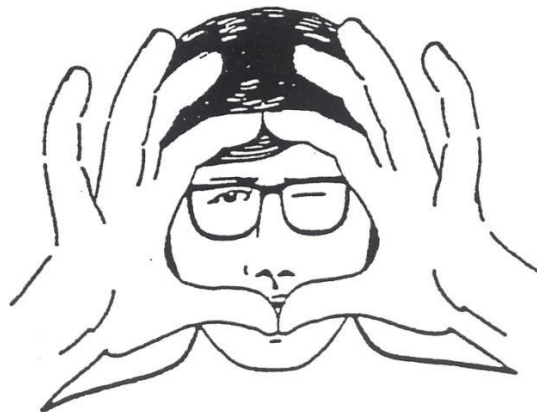
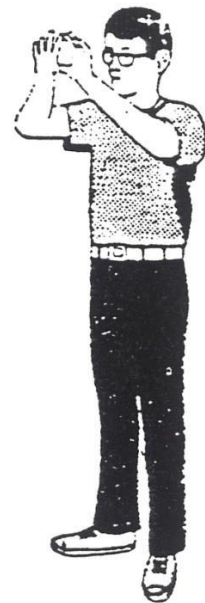
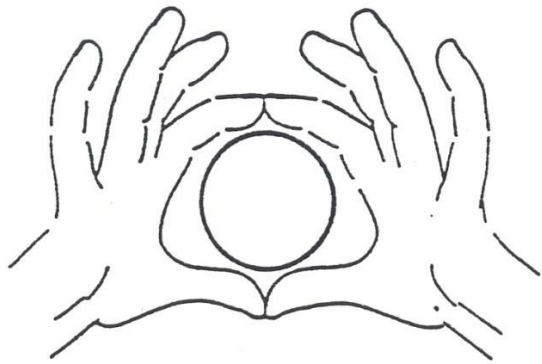

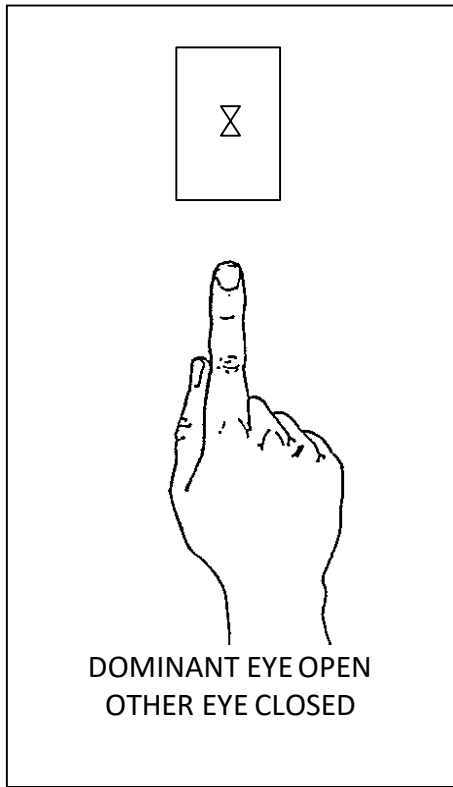

Check for Eye Dominance

With both eyes open, point your finger at a small object 10 - 20 feet from you.

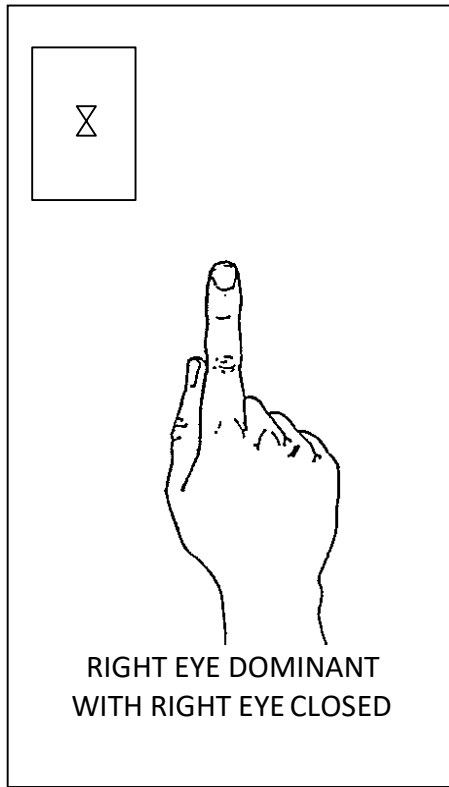

Right Eye Dominance

Close your left eye and the object will not move.

Close your right eye and the object will appear to jump to the left of your finger.

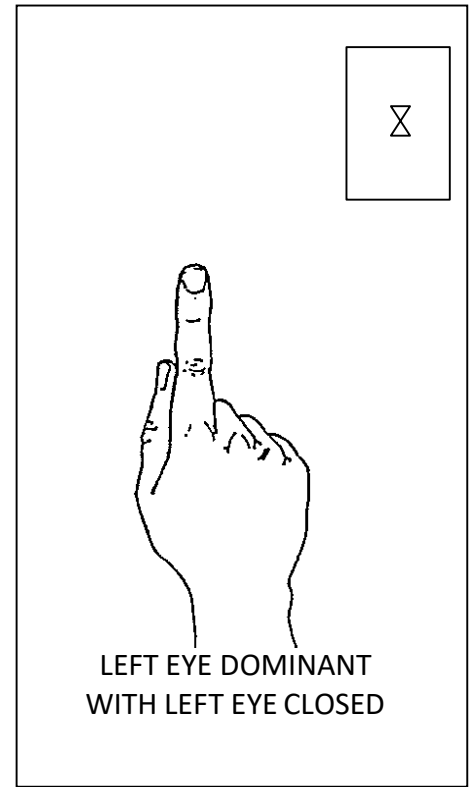

Left Eye Dominance

Close your right eye and the object will not move.

Close your left eye and the object will appear to jump to the right of your finger.

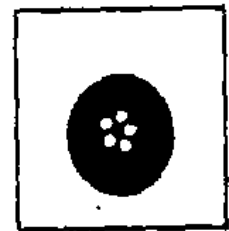
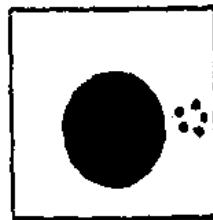
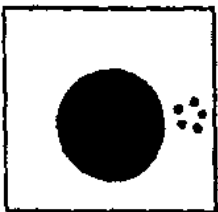
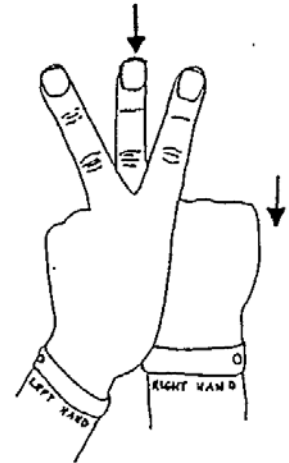
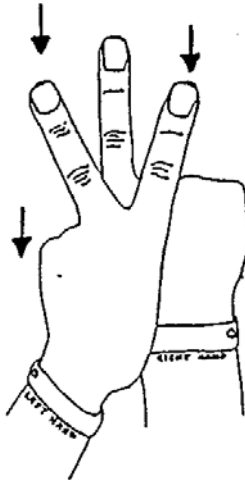
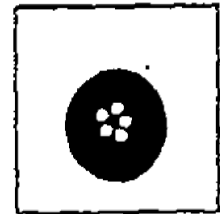
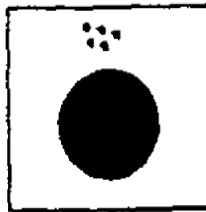
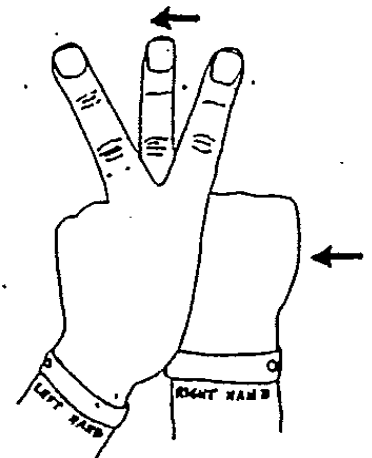
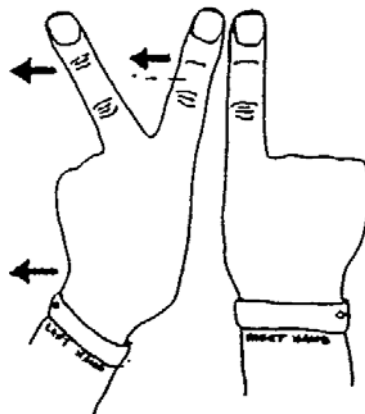

Figure B-1: Two fingers of left hand simulate rear sight. Index finger of right hand simulates front sight. Represents perfect sight alignment.

Figure B-2: Keeping right hand stationary, move left hand to the left to simulate moving rear sight to the left.

Figure B-3: After the rear sight (left hand) is moved left, realign sights. Thus, right hand moves left 10 simulate moving muzzle left.



Non-threatening Hands-on Instruction

James V. Peter, Jr.*

A major element of shooting is stance. When working with shooters, particularly beginners, instructors frequently must use their hands to position them or correct their form or assisting them with equipment and shooting clothing. Even though close contact with the shooter is essential for effective instruction, the instructor must be careful to avoid any action that could appear improper or cause the student anxiety. A few simple actions can ensure a working relationship between instructor or coach and student without any question of anxiety or impropriety.

Respectful, non-threatening treatment of shooters begins with demonstration. Use a junior leader or an assistant to demonstrate proper posture or position and then as to how instructors will handle/assist shooters to correct their posture or position. By telling the shooter what you are about to do you can further reduce his or her anxiety. Ask permission before touching and tell the shooter you are going to push his or her torso forward, raise an elbow or reposition a hand. The posture of your hands when contacting the student can also ease anxiety. Except in an unsafe situation where immediate and decisive action is required, it is

seldom necessary to “grab” a student or the firearm. When your hands are held relatively rigid with the fingers straight and the thumbs resting on the top of the hands, they are much less threatened. Pressure from the palms of flattened hands (fingers not curled) can accomplish most positioning and controlling needs. This is called “Non-threatening Hands On Instruction.”

Non-Threatening Hands On Instruction

- Positioning or Stance
- Equipment & Shooting Clothing
- Always Respectful
- Use Demonstrations
- Request Permission to touch
- In response to students need
- Avoid Breasts, Buttocks, and Groin
- Should Be Open & Not Secretive
- Governed by Age
- Always Appropriate When Safety of the Individual or Group is At Stake

Examples and Advice

Assisting with coats, shooting vests or shooting coat or jacket. There are a number of adjustments that can be made on a shooting jacket/coat that

help the fit and performance of the individual. As we teach in instructor training there are appropriate methods and inappropriate ways of non-threatening hands on instruction or assistance. Utilizing same gender assistance or students helping students may be the most appropriate for the situation. Age of participants, gender, and individual permissions are also factors that must be considered. The one exclusion is when the immediate safety of the individual or others is at stake.

Trajectory and Trajectory Experiments

Ronald A. Howard Jr. *

Many people think that bullets, shot or arrows travel in straight lines just like light. It does not take much shooting experience to realize that projectiles and light behave quite differently. The physics of projectiles (ballistics) is discussed at the end of this fact sheet for those interested. The main purpose of this material is to help you understand how trajectory enters into shooting.

Under normal conditions, light travels in straight lines. Changes in the density of substances it passes through may deflect it, but within substances of fairly uniform density (like air) light travels in straight lines. Electromagnetic forces, like magnets can bend light, but it has no mass (weight).

Projectiles like bullets or arrows have mass. As a result, they respond to gravity under normal conditions. As soon as an arrow leaves the string or a bullet leaves the muzzle, it begins to fall, accelerating toward the earth under the influence of gravity. In fact, if an arrow or bullet was fired parallel to the surface of the earth on level ground, it would hit the earth at the same time as one dropped from the same height at the same time much farther away. In addition to their mass, projectiles are solid objects. Pushing them through a dense medium, like air, causes friction and turbulence. Both forces affect the projectile immediately. The projectile begins to slow down as soon as it leaves the string or the muzzle.

The slowing influence is cumulative until the projectile finally comes to rest.

These two factors combined cause projectiles to follow a curved flight path. If two straight lines are used to show the line of the bore or the resting position on the string and the line of sight, the line of flight (path of the projectile) would relate to those lines as shown below (Figure 1).

The curved flight path requires that

the bore must be pointed above the line of sight to hit a distant object on the line of sight. If the sights are above the bore or the arrow, it must cross the line of sight twice, once while rising and a second time while falling toward the earth. The exact shape of the trajectory curve can be determined by complicated mathematics or by testing. Actual testing yields better results for a given shooter and his or her equipment and is more easily understood.

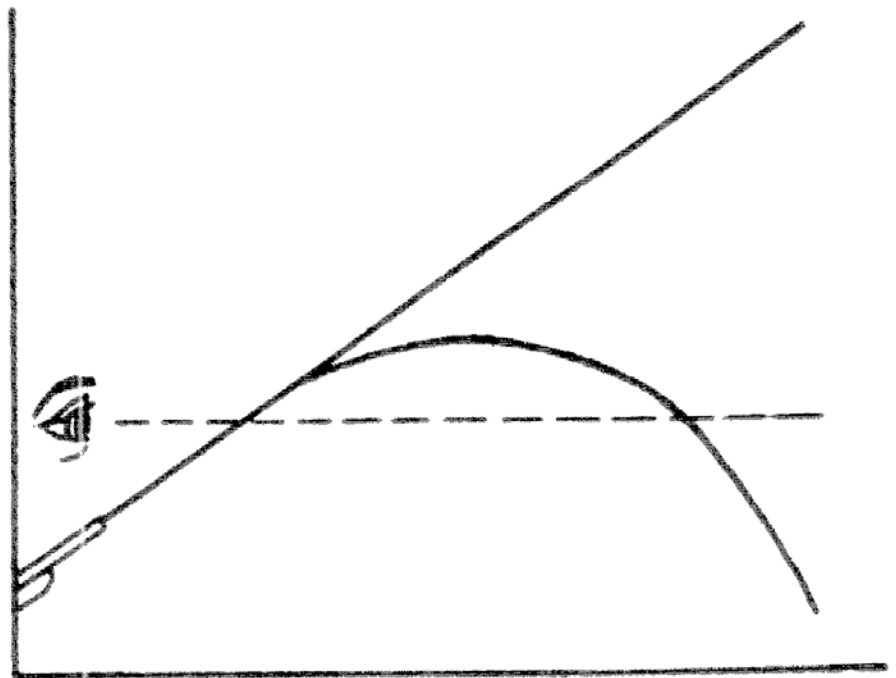

Figure 1. Relationships among line of sight, line of bore, flight path and drop.

* 4-H and Youth Development Specialist, Texas Agricultural Extension Service

The projectile accelerates toward the earth at a rate of about 9.8 meters/second² (32 feet per second²). If the projectile was fired parallel to the ground, it would drop 4.9 centimeters (0.16 feet) in the first 0.1 second, 9.6 centimeters (0.64 feet) in 0.2 second, 122.5 centimeters (4 feet) in 0.5 second, and 490 centimeters (16 feet) in 1 second (Table 1). In seconds it would have dropped 44.1 meters (144 feet). If a projectile were able to travel at a constant velocity of 60.96 meters/ second (200 feet/second), the trajectory would look like the graph in Figure 2. The actual flight path would curve more sharply downward, since the projectile would be slowing its horizontal motion as gravity pulls it to earth.

You can calculate the trajectory of your personal equipment as you have it set up using the worksheet attached. Shoot the same arrows throughout the experiment if possible. If not, shoot matched arrows with matched fletching. Leave the sight setting the same for all shots, and use the same aiming point for each shot and all distances. Measure from the aiming point to the center of the group of arrows and carefully record the distance above (+) or below (-) the point of aim for each distance. Stop shooting if the arrows are falling short (or nearly falling short) of the target. Plot the flight path of the arrows relative to the line of sight. The elevation angle can be calculated if desired by following these steps.

1. Measure the true draw length of the arrow at full draw (the distance from the anchor point to the arrow rest).

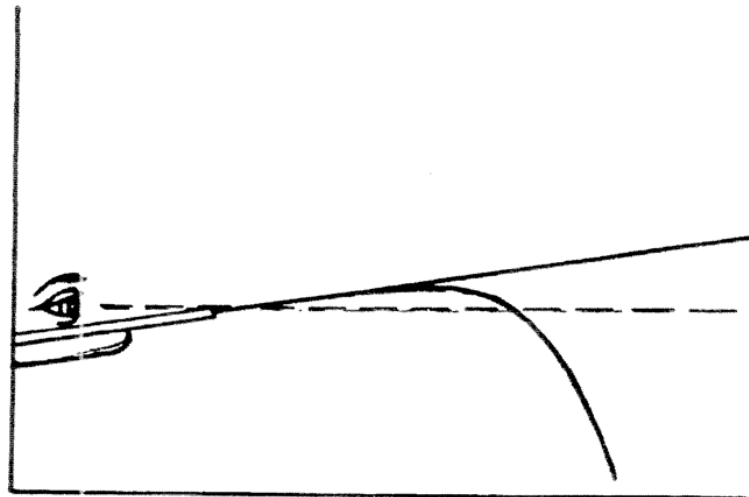

Figure 2. Trajectory of an idealized projectile traveling at a constant 60.96 meters/second (200 feet/second).

2. Measure the height of the sight pin above the arrow rest.
3. Measure the height of the center of the eye above the bottom of the arrow shaft at the anchor point.
4. Subtract the sight pin height from the eye height.
5. Divide that length by the true draw length.
6. The dividend is the natural sine of the angle of elevation from the horizontal.
7. Use a sine table to locate the angle with that sine value.
8. Plot a horizontal line through the eye and sight to the center of the target.
9. Plot a line starting with the distance from the eye to the anchor point below the line of sight at the calculated angle of elevation above horizontal. This is the line of the shaft or the line of the bore.
10. Plot the true line of flight at the distances selected.

This same procedure can be used with rifle bullets, but a longer range is needed and the differences in impact points should be recorded in centimeters or inches rather than meters or feet.

For Those Who Want to Know More

Ballistics is the science of projectiles. It focuses on the dynamics of projectile flight and the energy stored and released by the projectile. One of the components of ballistics is the study of trajectory, the flight path of projectiles. In shooting, trajectory related the straight line of sight to a target with the curved flight line of the projectile. The ballistics of bullet or arrow trajectory involves complex concepts in physics and engineering.

Newton's first law, the law of inertia, states that objects tend to remain at rest or to travel in a straight line at a constant speed unless they are acted upon by an outside force. For projectiles, the forces include the energy that accelerates them initially, the acceleration of gravity, friction of the air and drag. Projectile mass, shape and even construction can influence those forces. Complex formulas have been developed to calculate the projectile's ability to retain its energy and velocity

(speed in a direction). Sectional density and ballistic coefficient are two measures of the “slipperiness” of a projectile.

A projectile starting at rest is accelerated by the stored energy of the limbs, air charge or expanding gases of the fired round. The internal ballistics (those inside the firearm bore or while the arrow is on the rest) limit the motion to horizontal and vertical vectors (components of the total velocity of the projectile). Under most conditions the horizontal velocity is greatest.

External ballistics are more complex, and they begin as soon as the projectile leaves the bore or the bow. The horizontal vector of velocity is measured by its horizontal speed toward the target. The vertical vector is measured by its speed upward, perpendicular to the surface of the earth. Both the horizontal and the vertical vectors of velocity begin to decrease immediately. Friction and turbulence in the air reduce the horizontal velocity. The pull of gravity reduces the vertical velocity. Note that a negative acceleration or velocity in the vertical component means the projectile is moving toward the earth rather than away from it. Wind currents or the rotation of the projectile may cause a lateral movement.

High initial and retained velocities result in a “flatter” trajectory. That is, the arc of the projectile from the shooter to the target is less peaked. The less time the projectile is in flight, the less outside forces influence it. The obvious conclusion is that “faster is better.” However, obtaining optimum ballistic performance involves balancing competing factors rather than simple maximization of any one factor.

Limits are imposed by the chemical structure of the powder, strength of the materials used, mass of the firearm and the strength or recoil resistance of the shooter. Other factors, like barrel life, consistency in energy release, economics, projectile construction and many more reduce the upper limit toward some optimum value.

Changing a single factor of the internal ballistics can result in major changes in external ballistics. Altering the mass of a projectile results in changing its shape. Both Sectional density (a measure of the mass divided by the diameter or basal area) and ballistic coefficient (a measure of the bullet’s ability to overcome resistance of the air, which involves sectional density in its calculation) are related to the shape of the bullet. Optimizing mass and initial velocity with performance and terminal velocity involves many factors.

The results of changing bullet mass may be surprising. An empirical test could be done using bullets of similar shape and diameter but different weights. Thirty caliber bullets are available in flat-based spitzer shapes in weights from about 110 grains to 200 grains. Interested shooters could fire a test series with bullet weight and compare trajectory curves to determine the optimum bullet weight for that shape in their rifle.

Both momentum and energy are related to the velocity and mass of the projectile. Momentum is the product of the mass and the velocity. Kinetic energy (the energy of moving objects) is the product of the mass and the square of the velocity divided by two.

Projectile use is a major determining factor in balancing momentum and energy. When a projectile comes to rest, the remaining energy and

momentum are translated into penetration and shock. On target ranges bullets and arrows need only enough momentum and striking force to penetrate the target. The shot must have enough remaining energy and momentum to break clay targets. In hunting situations, small game arrows, shot and bullets kill by hydrostatic shock. The energy of the striking bullet displaces water in the tissue, causing immediate disruption of vital functions.

Momentum is not critical, but kinetic energy is. Big game arrows kill by penetration and hemorrhage. Very little hydrostatic shock is produced, so momentum is much more important than kinetic energy. Big game bullets must combine shock with adequate penetration to reach vital areas. Considering the use of the projectile adds complexity to making ballistic decisions. This may explain the large array of arms and ammunition available today.

Many ballistic experiments can be tried by shooting sports participants. Most would be worthy of entry in science fair competitions under the categories of physics and engineering. Altering one factor at a time, such as sectional density or velocity, may offer easier explanations of the events taking place. For the shooter, more interested in performance on targets or game, the arms and ammunition companies have tables that can assist in selecting the appropriate combinations of factors to do the job at hand. Wise shooters will test the listed values for themselves using their own firearms, particularly where the shape of a trajectory curve is concerned. Their observed data is much more valuable than the theoretical data from the tables.

Table 1. Theoretical values for drop from the acceleration of gravity and distance traveled for idealized projectiles fired parallel to the surface of the earth at a constant velocity of 60.96 meters/second (200 feet/second) and 914 meters/second (3000 feet/second) is given below. The lower velocity corresponds to a very fast arrow. The higher velocity approximates a high velocity center-fire rifle cartridge.

Time	Distance Dropped		Distance Traveled @200ft.sec		Distance Traveled @3000ft.sec	
	(sec)	(cm)	(ft)	(m)	(ft)	(m)
0.1	4.7	0.16	6.1	20	91.4	300
0.5	19.6	0.64	12.2	40	182.8	600
0.3	44.1	1.44	18.3	60	271.2	900
0.4	78.4	2.56	24.4	80	365.6	1200
0.5	122.5	4.00	30.5	100	457.0	1500
0.6	176.4	5.76	36.6	120	584.4	1800
0.7	240.1	7.84	42.7	140	693.0	2100
0.8	313.6	10.24	48.8	160	731.0	2400
0.9	369.9	12.96	54.9	180	822.6	2700
1.0	490	16.00	61.0	200	914.0	3000
1.25	765.6	24.00	78.2	250	1142.5	3750
1.5	1102.5	36.00	91.4	300	1371.0	4500
1.75	1500.6	49.00	106.7	350	1599.5	5250
2.0	1960	64.00	121.9	400	1828.0	6000

Pistol and Rifle Range Commands

William F. Stevens, John Kavsnicka and Ronald A. Howard, Jr.*

Basic range control procedures are familiar to most rifle or pistol shooters. After shooters become familiar with range operations, behavior and etiquette use the conventional range commands. When new shooters are learning, however, modifications can enhance safety and provide better control. The following procedure is effective and we recommend it to you. Range commands are in bold type. Coach, shooter or range assistant actions and comments are listed in normal type. Options or temporary parts of command are indicated by brackets [] Parentheses () enclose alternative or additional commands that can be used with beginning shooters. Refer to Fact Sheet 13 for additional information.

Shooters (Relay {state number}) to the line.

Shooter-coach pairs move to the firing line with their rifles or pistols empty, actions open and exposed to view, muzzles pointed in a safe direction and fingers off the trigger. Range staff will also check each rifle or pistol on its way to the range.

Is the line ready? Respond by firing point number, please.

Each shooter or coach will reply with “ready” or “not ready” and state his or her firing point number. Any firing point not responding will be queried directly to determine their situation and whether they need assistance. Once the line is ready, the range officer will declare its status.

The line is ready. [The range (line) is clear, you may handle your firearms (pistols, rifles).]

OR

Pick up your firearm (pistol, rifle). Keep the muzzle down range, the action open, the safety on and the finger off the trigger.

Shooter pick up rifles or pistols, verify the condition, make any preparations with the empty rifle necessary for the shooting taking place and await further instructions. “Coaches” and range assistants observe muzzle control and maintain control over all ammunition. *See the Fact Sheet 17: Pistol and Rifle Shooting Procedures* for further information.

Load your firearm (rifle, pistol).

Safeties off.

Assume a comfortable (proper) firing position.

Align your sights. (Focus on the front sight and obtain proper sight alignment.)

[Raise your pistol (rifle) to firing position. (Keep the front sight in focus and maintain your sight alignment.)]

Obtain a proper sight picture. (Maintain your focus on the front sight and proper sight alignment.)

Fire when ready.

Squeeze (Press) the trigger. (Maintain your front sight focus, sight alignment and sight picture until the projectile {bullet, ball or pellet} hits the backstop.)

Cease fire.

The cease fire command must be obeyed immediately, even if a shot is nearly ready. It is complex and will need step-by-step reinforcement until it is nearly reflexive.

Make your firearm (rifle, pistol) safe. [Keep the muzzle pointed down range.]

Open the action and make sure all ammunition is removed from the firearm. Place the safety in the “on” or “safe” position.

Ground your firearm (rifle, pistol), leaving the action open and score targets.

Firearms may not be handled until the range has been declared clear once more.

Conventional Range Commands

Relay [X] (shooters, relay [X] match [Y]) to the line.

* Conservation Affairs Manager for Federal Cartridge Company, Anoka, MN; Executive Director, Minnesota Deer Hunters Association; and 4-H and Youth Development Specialist, Texas Agricultural Extension Service.

The preparation period begins now...The preparations period has ended

This command declares that the range is clear and unloaded firearms may be handled, adjusted or otherwise made ready. They may NOT be loaded.

Is the line ready?

Any shooter not ready must indicate he or she is not prepared to begin their relay. If any shooter is not ready, the range officer will announce that **the line is not ready** and repeat the process after a brief pause.

The line is ready.

This command indicates that all shooters have completed their preparations and are ready to begin the relay.

Ready on the right. Ready on the left. Ready on the firing line.

This command announces that the firing line is active. In some events, the shooter may insert a magazine or load after the “ready on the right” command.

Commence firing. (Fire when ready, fire at will, the range is hot.)

Live firing may commence. The first two terms are more commonly used. Their use is encouraged to promote consistency.

Cease firing. [Unload, open the action, ground your firearm.]

The initial command carries the implication of all the others, but they are used explicitly in some shooting events.

Change (score or score and paste) targets. (The range is clear, you may change targets.)

Shooters may proceed down range to replace, retrieve or score targets. Firearms may not be handled until the range has been declared clear once more.

Several additional commands may be used.

The firing line is clear. You may handle your guns.

This is equivalent to the “make ready” command.

Police firing points.

This command is used when shooters need to pick up their fired brass and other materials around the firing points, often at the end of one or more relays.

As you were.

This command rescinds the one immediately preceding it. It returns control to the previous level, for example, if the range officer has announced “the line is ready,” “as you were” would indicate that it is not ready.

Carry on.

This command allows shooters to proceed with the actions taking place before some interruption occurred.

Make your firearms (pistols, rifles) safe.

The range officer may include or expand this command. The firearm should be unloaded, magazines removed and actions or cylinders opened and plainly exposed to view. Muzzles must continue to point down range.

Ground your firearms (rifles, pistols).

The safe firearm must be placed on the shooting mat, bench or other safe surface. It may not be picked up or handled without specific instruction from the range officer.

Each action is the same as for beginning shooters above. Do not rush to move to the “standard” range commands. The beginning shooter will benefit from the verbal reinforcement of the positive actions they should be taking. Move to the conventional commands after you are completely satisfied that the fundamentals of firing a shot and range safety are instilled in the shooters.

Rifle and Pistol Shooting Procedures

Ronald A. Howard, Jr., William F. Stevens and John Kvasnicka*

Beginning shooters must learn a protocol for handling firearms on the line. Instructors or coaches should use an expanded procedure to establish and reinforce safe and responsible firearms handling. Once those processes have become conditioned reflexes, control may revert to the basic range control commands. The protocols outlined here are designed to produce safe and responsible shooters. Numbered items are the basic commands. All items in bold print should be explicitly mentioned during the shooting process for beginning shooters.

1. Pick up your firearm [rifle, pistol]. Several elements are implicit in this process.

Keep muzzles in a safe direction. That means down range while on the firing line and away from people (usually straight up) at all other times. Take time to teach a proper position. Muzzle control is the shooter's personal responsibility with the coach and range personnel reinforcing it constantly and having immediate access to each shooter.

Check firearms to be sure they are empty. Verify that each firearm is empty. Control of all ammunition by range assistants or coaches is essential during the early stages of instruction.

Actions open and exposed to view for visual inspection. A closed action means "loaded and ready to fire." This, too, is a shooter's responsibility with reinforcement from their coach and all range staff.

Keep fingers off the trigger until in the act of firing. Until keeping the finger along the trigger guard becomes a habit, all range staff must watch this carefully.

Safeties on. The location and operation of the safety must be thoroughly explained. Define what is meant by "safe" or "on" and "fire" or "off." [Note: Instructors debate the importance of using the safety during range instruction. Many feel it is unnecessary since the firearm is only loaded when a shot is going to be fired. They consider using the safety unnecessary and potentially confusing. Many others feel use of the safety reinforces proper firearms handling and prepares the shooter for field shooting.]

2. Load [and charge] your firearm. Safe loading, unloading and charging (air rifles) must be thoroughly demonstrated and explained. Even when coaches will be loading the firearm, reinforce the process step by step early in instruction. Each coach and shooter must be sure the ammunition provided is appropriate to the firearm being used. When dry

firing, **absolutely no live ammunition** should be on the firing line, or in the possession of anyone on the firing line. Ammunition must be distributed through range staff or coaches until shooters can handle their own.

Place one round in the changer. If air guns are used, remind shooters that the skirt of the pellet goes to the rear, at least for the first few shooting sessions.

Close and lock the action. Reverse this sequence to unload a firearm.

Charge the arm [rifle, pistol] with air. To ensure consistent performance, explicit instructions may be needed in the early stages of instruction.

3. Assume a proper shooting position. The coach and range staff should assist each shooter into a proper shooting position, oriented and positioned for effectiveness. Each point in the position should be checked to give the shooter advantage. During the early stages of instruction the position, including foot position orientation to the target, stance, grip and other form elements should be developed gradually and in sequence.

* 4-H and Youth Development Specialist, Texas Agricultural Extension Service; Conservation Affairs Manager for Federal Cartridge Company, Anoka, MN; and Executive Director, Minnesota Deer Hunters Associations.

4. Safety off.

5. Align your sights. In the beginning, consider this a two- step process.

Focus your vision on the front sight. Align the front and rear sights.

6. Fire when ready. The firing process is complex and should be considered in a step-by-step fashion for beginning shooters. Often the first shot is fired “by commands.”

Obtain sight alignment and sight picture.

Squeeze the trigger (press the trigger straight back) while keeping the sights aligned, focusing on the front sight and maintaining your sight picture.

Maintain the sight alignment and sight picture through the shot until the projectile strikes the backstop.

7. Cease fire. The cease fire command is also complex and requires step-by-step reinforcement.

Cease fire. [Reinforce immediate response.]

Make your firearms [pistols, rifles] safe.

Open all actions.

Remove all ammunition.

Ground all firearms [rifles, pistols] with the actions open and visible for inspection.

Take one step back from the firing line.

RANGE COMMANDS

“SHOOTERS TO THE LINE”

“YOUR PREPARATION PERIOD STARTS NOW”

“THE LINE IS READY?”

(Extended Reply – “Ready” or “Not Ready” by firing point number)

“THE LINE IS NOT READY”

“THE LINE IS READY”

“COMMENCE FIRING.”

“CEASE FIRING.”

“MAKE THE LINE SAFE” “IS

THE LINE IS SAFE?” “THE

LINE IS NOT SAFE” “THE

LINE IS SAFE”

“YOU MAY GO FORWARD”

Trigger Squeeze

Ronald A. Howard Jr.*

Proper trigger control involves moving the trigger mechanism to fire a shot without disturbing sight alignment or sight picture. Rifle and pistol shooters commonly refer to this process as “squeezing the trigger.” Although “squeeze” may imply a prolonged pressure rather than a swift movement, it may carry some unintended messages for the shooter. Squeezing a rifle or pistol trigger must be an isolated action. It requires that pressure be exerted straight back on the trigger by the trigger finger alone. Squeezing with the rest of the hand or attempting to force the shot into the desired area by snatchin or jerking the trigger is a serious form fault that may be difficult to cure. Using the entire hand or the thumb in the trigger squeezing process can have a serious impact on group size and location. Although it affects both rifle and pistol shooting, its impact on pistol marksmanship is much more evident. The

coach or instructor must be conscious of the potential problem and be prepared to treat it.

Thumbing or squeezing the grips can be diagnosed by reviewing the location of groups on the target. Dry-firing or ball and dummy exercises may reveal the problem more graphically. Practice can cure the tendency to grab, grasp or thumb; but the problem is easier to prevent than to cure.

Be sure to explain what trigger squeeze is and is not to naïve shooters. It may help to use other terms for the process. Many coaches like to use “press” since it conveys the same sense of prolonged pressure, but does not imply action by the remainder of the hand. Caution former military shooters to avoid using the analogy of squeezing a lemon or other item with the entire hand. The amount of grip pressure should remain consistent from shot to shot and during the shot.

A simple exercise can help in teaching trigger control. Have each shooter hold their shooting hand in a relaxed manner but in the position it would assume to hold a pistol. Ask them to practice removing the tip of their trigger finger back toward the wrist without moving the thumb or the other fingers. This exercise helps to develop a smooth trigger squeeze while avoiding extra muscular activity and tiny disturbances in sight alignment and sight picture. It has the advantage of requiring absolutely no equipment.

The more traditional, eye dropper technique is also excellent if thumb movement is carefully avoided during the squeeze. The eye dropper could even be mounted in a pine stock if desired.

* 4-H and Youth Development Specialist, Texas Agricultural Extension Service.

Penetration and Shock Demonstrations

Ronald A. Howard Jr.*

This demonstration is an effective way of contrasting the actions of firearms and archery equipment. It requires an adequate range. For best results, use a high velocity cartridge loaded with frangible bullets in the rifle. A bow powerful enough to completely penetrate the backstop material completely should be used. Have junior leaders or parents assist.

First, shoot water filled (completely!) milk jugs, oil cans or similar containers with each arm. The targets should be at the same range from the firing line and close enough to hit them easily. The rifle should produce a response resembling an explosion. The bullet has high

kinetic energy that is quickly transferred to the water as hydrostatic shock. Since water is incompressible, it moves away from the impact area violently. Water in living things behaves similarly, and the bullet kills by tissue disruption and hydrostatic shock.

The arrow should easily penetrate both sides of the jug, and may pass through the container without too much disturbance, merely causing a leak or making the jug tip over. It has relatively little kinetic energy and causes very little hydrostatic shock. Arrows are penetrating and cutting projectiles, and they kill large game by massive and rapid hemorrhage.

Repeat the performance on jugs filled with sand, hay bales or some similar backstop. The rifle bullet should be stopped by the material, but the arrow should pass completely through again. This should help the youngster to realize that even a relatively light bow has the ability to drive an arrow through material that is capable of stopping a bullet. Use the graphic demonstration as an introduction to a discussion of safety and the functions of both bullets and arrows in taking game animals.

* 4-H and Youth Development Specialist, Texas Agricultural Extension Service.

Air Gun Range Setup

Donald L. Burtchin*

There are a number of reasons for using BB guns, air rifles, and air pistols rather than conventional firearms in a shooting sports training program. One is the lower cost of equipment and ammunition. Second is that the safety requirements and marksmanship skills needed when shooting conventional firearms are easily taught when using air guns. Another advantage in using air guns is the minimal space required for an air gun range. A simple air gun range can be set up indoors or outdoors, as long as safety requirements are observed.

Air gun ranges can be set up in locations where conventional firearms ranges cannot be used because concerns about cost, noise, weather and a variety of other conditions exclude them. An indoor air gun range does not need the expensive ventilation and filtration system for toxic lead fumes and particulate matter that is required for a conventional indoors firearms range. Outdoor air gun ranges require much less space than conventional firearms ranges and they do not attract the attention of neighbors.

Safety Considerations

When you are planning to set up an air gun range, you need to consider the following topics in your plan:

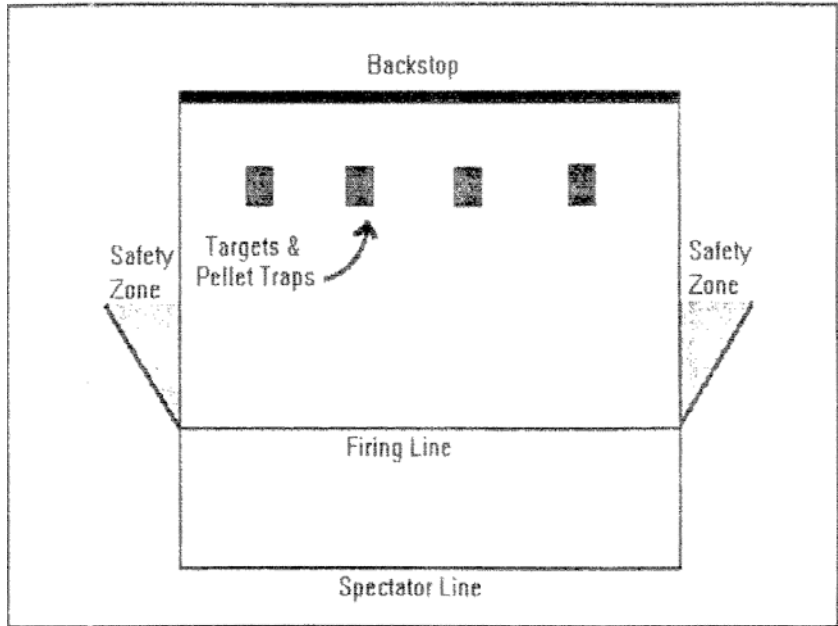

Air Gun Range Diagram

- The RANGE of the air gun;
- The PENETRATION of the projectiles;
- The possibility of RICOCHETS; and PERIMETER SECURITY to prevent people and animals wandering into the range.

Range and Penetration

The RANGE and PENETRATION of air guns will vary with the types of gun. It is reasonable to expect a simple spring-powered BB gun to shoot a BB several hundred feet.

Compressed gas pellet guns may shoot a pellet several hundred feet. Compressed gas pellet guns may shoot a pellet several hundred yards or more. Specific information is available from the gun manufacturer.

Ricochets

All projectiles have a tendency to RICOCHET when they hit a hard surface and do not penetrate it. Projectiles from air guns are relatively low-powered and they are used for shooting at fairly short ranges, so ricochets need to be a particular concern.

* Volunteer, Arizona 4-H Shooting Education Volunteer Coordinator

BBs are quite hard and shot from low-powered guns. They readily bounce back at the shooter when they hit hard surfaces.

Pellets are made of soft lead. They deform and lose energy when they hit hard surfaces so they do not bounce back as strongly as BBs.

EYE PROTECTION must be mandatory for all shooters and instructor staff. Look for the ANSI Z87-1 rating on safety glasses to be sure they provide adequate protection. Spectators should be kept well back of the shooting line and encouraged to wear eye protection as a precaution.

Perimeter Security

PERIMETER SECURITY is essential to prevent people and pets from wandering into the range area. Air guns make little noise, so sound will not alert people to the fact that the range is in operation. The range will need physical markers (surveyor tape, etc.) to delineate the boundaries and safety zones.

A SPECTATOR LINE should be established at least 15 feet behind the FIRING LINE to avoid crowding and distracting the shooters.

SAFETY ZONES should be established on each side of the range if it is outdoors. They should extend from the firing line at about a 30-degree angle to end of the range.

Distance From Firing Line to Target

The distance from the firing line to the target depends on the guns in use and the type of course to be fired. The following guidelines may be used.

- BB guns – 5 meters (16.4 feet) from the firing line to the target face.
- Air guns firing pellets – 10 meters (33 feet) is the usual distance from the firing line to the target face for most practice and target competition. It may vary from 25 to 45 yards for special courses of fire. If space is limited, targets may be set up at 5 yards for air gun practice.

Backstop Requirements

Good backstops are required to make sure projectiles do not go beyond the end of the range. Proper backstops also prevent the ricochets that occur when low-powered BBs and pellets hit a hard surface backstop. A backstop surface that absorbs energy will reduce the possibility of ricochets. Two backstops are commonly used on air gun ranges, a PRIMARY BACKSTOP and a SECONDARY BACKSTOP.

The PRIMARY BACKSTOP can be a commercially available metal pellet trap or a simple home-built pellet trap consisting of a cardboard box with a pellet-stopping interior. An effective pellet-stopping interior may be constructed by simply filling the

box with wadded newspapers and a few magazines in the rear of the box to completely stop the projectiles.

A loosely hanging piece of old carpet or canvas in the box will work with BB guns and pellet guns that have a muzzle velocity less than 550 feet per second (fps). Pellets at velocities greater than 550 fps may penetrate the carpet or canvas. If a piece of rubber-backed carpet is used, be sure to keep the rubber to the rear so that projectiles will not bounce back at the shooter.

Always use tape to secure targets to the cardboard box backstop. Thumb tacks, clothes pins, spring clamps, paper clips, and other hard fastening devices can cause ricochets.

If a commercially available pellet trap is to be used, be sure to read the manufacturer's specifications to be sure the trap is appropriate for the air gun to be used.

Also, be sure to follow the manufacturer's recommendations regarding targets and the method of fastening the target to the pellet trap.

A SECONDARY BACKSTOP is needed to stop any projectiles that miss the primary backstop. Several suggestions for a secondary backstop include;

- A large piece of loosely hanging canvas or old carpeting;
- Bales of hay;
- A soft dirt bank;
- A large metal plate angled down at 45 degrees to direct

projectiles into the ground
or

- Any other type of protective barrier that will stop the projectiles and not cause ricochets.

Caution: If loosely hanging canvas or carpet is used, leave the sides and bottom hanging loose. Depending on the material, projectiles may

ricochet or penetrate the material if it is tightly secured. Also keep in mind that projectiles traveling over 550 fps may penetrate the material.

NOTE:

Information on muzzle loading ranges can be obtained from the National Muzzle Loading Rifle Association, P.O. Box 67, Friendship, Indiana 47021.

Information on conventional rifle and pistol ranges can be obtained from the National Rifle Association, Range Division, 11250 Waples Mill Road, Fairfax, Virginia 22030-9400

BERM

TARGET AREA
(NO MORE THAN 5 YARDS FROM BERM)

FIRING ZONE

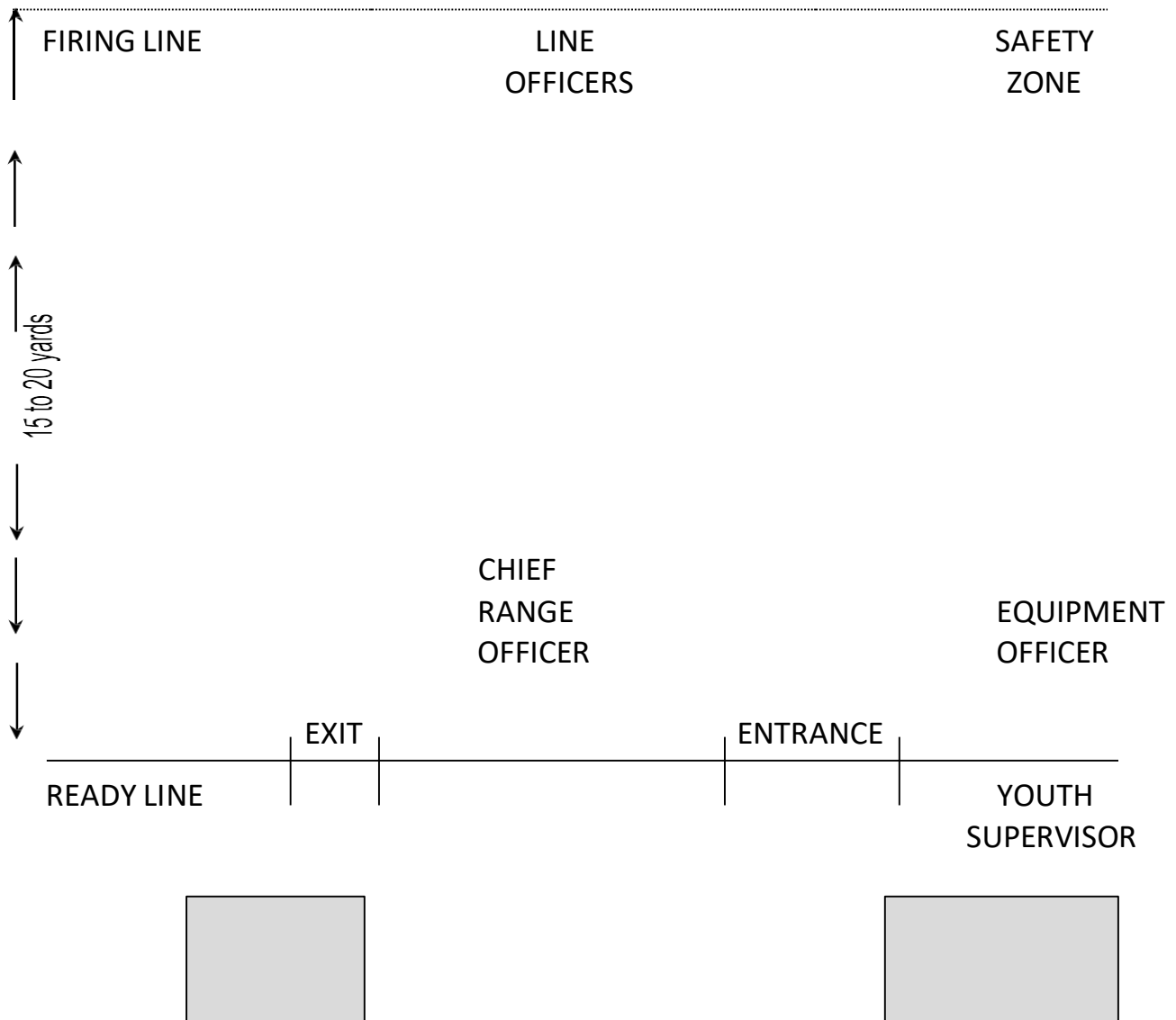

1 1/2" PVC PIPE

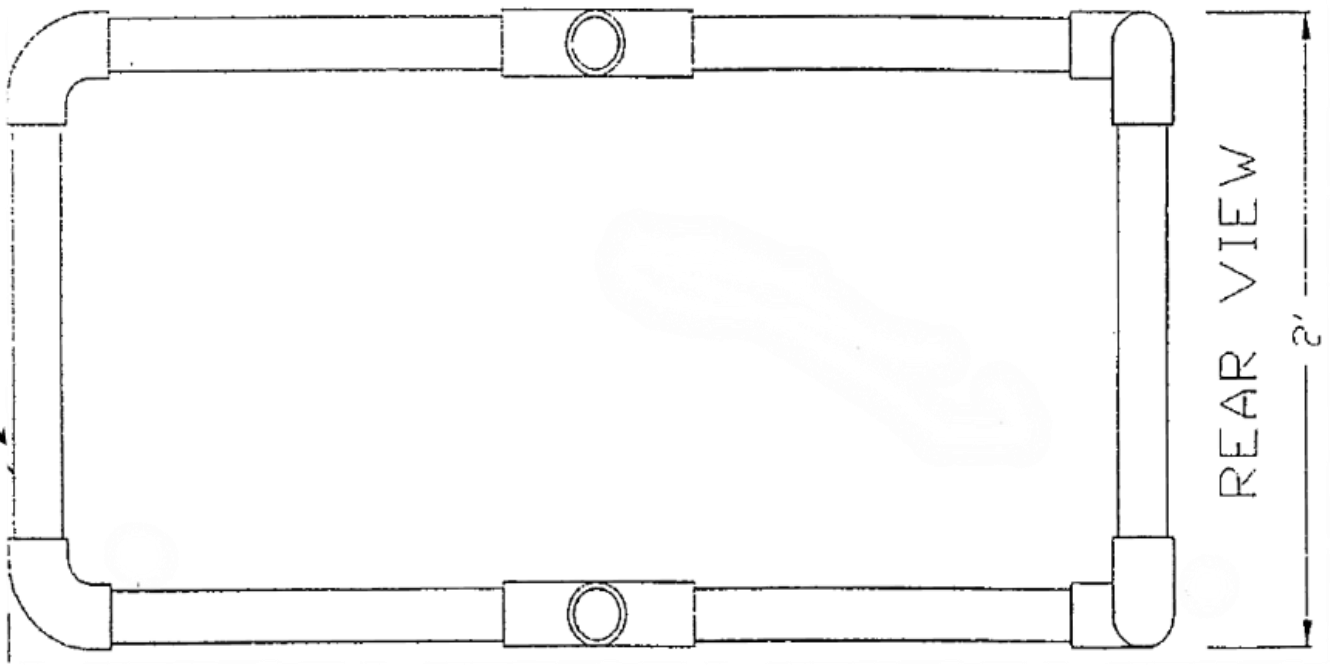

2' X 3' CARDBOARD

DRILL THROUGH FOR 3/8" HDW (SCREW AND NUT) (YOU MAY USE WING NUTS) 6 PLACES

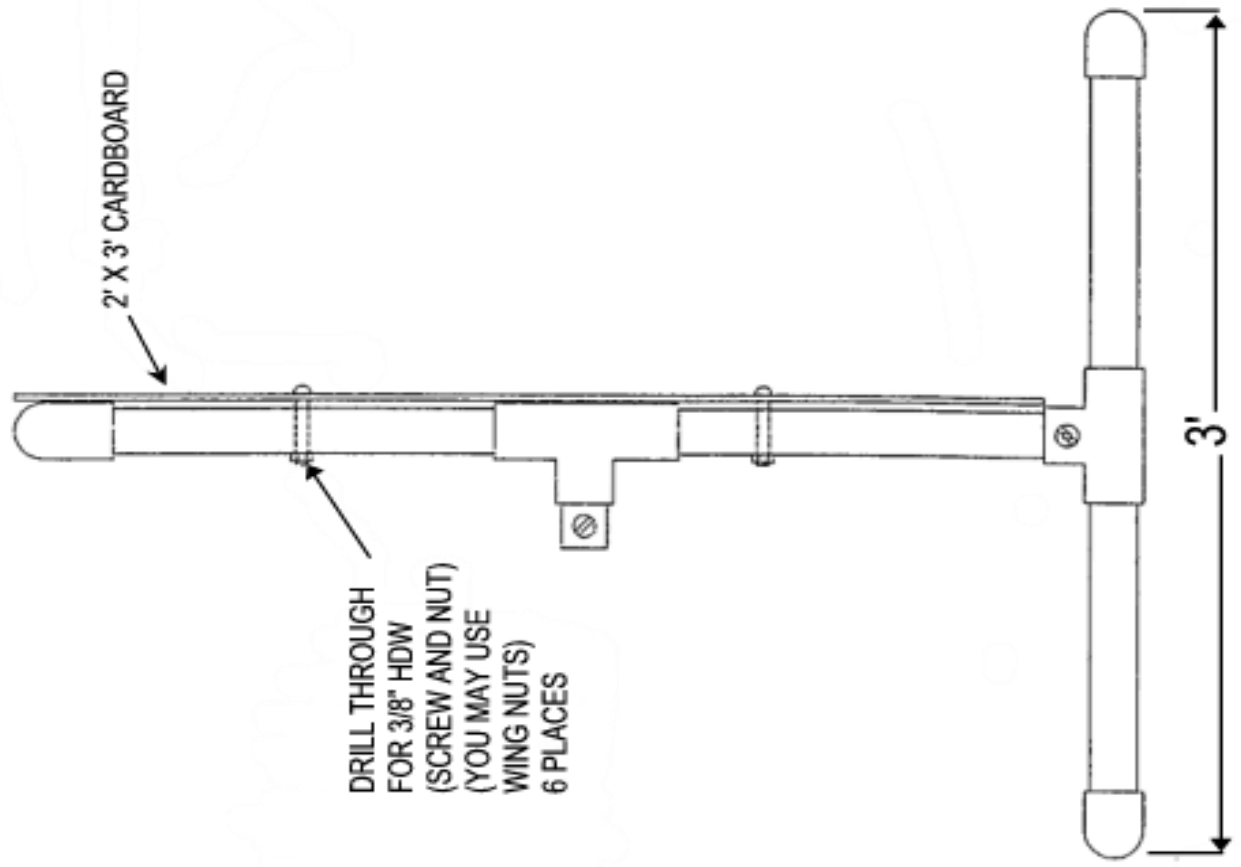

5 Meter BB Gun Back Stop

Material Needed:

- 1 - Cloth 19 1/2" x 60"
- 1 - Rope 15" Long
- 3 - 1" x 2" Furring Strips
- 2 - 1/4 x 20 x 2" Stove Bolts
- 2 - 1/4 x 20 Nuts
- 4 - 1/4 x 1 1/4 Fender Washers
- 12 - #8 x 1 1/4 Wood Screws

☞ Drill holes for wood screws

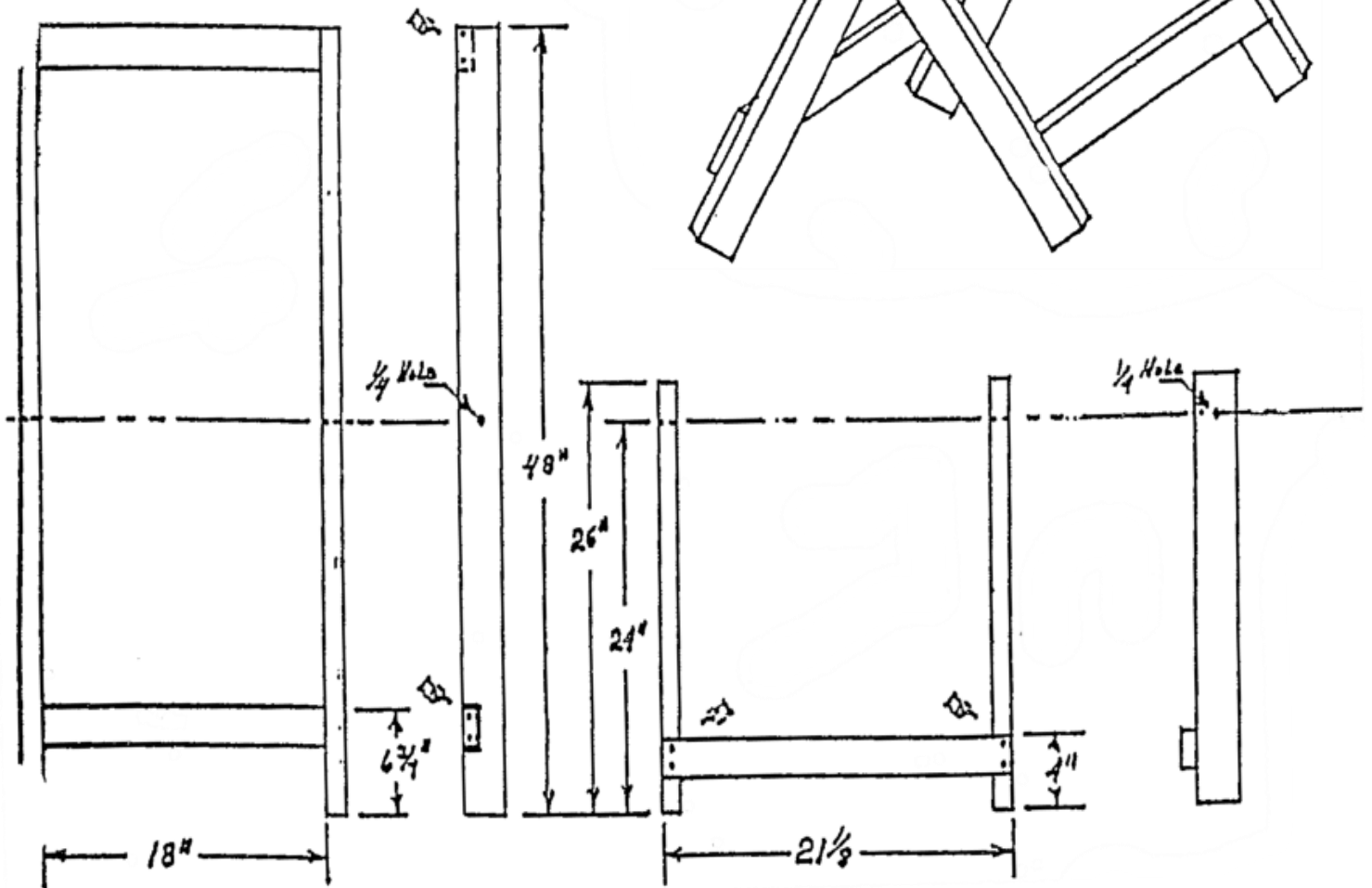
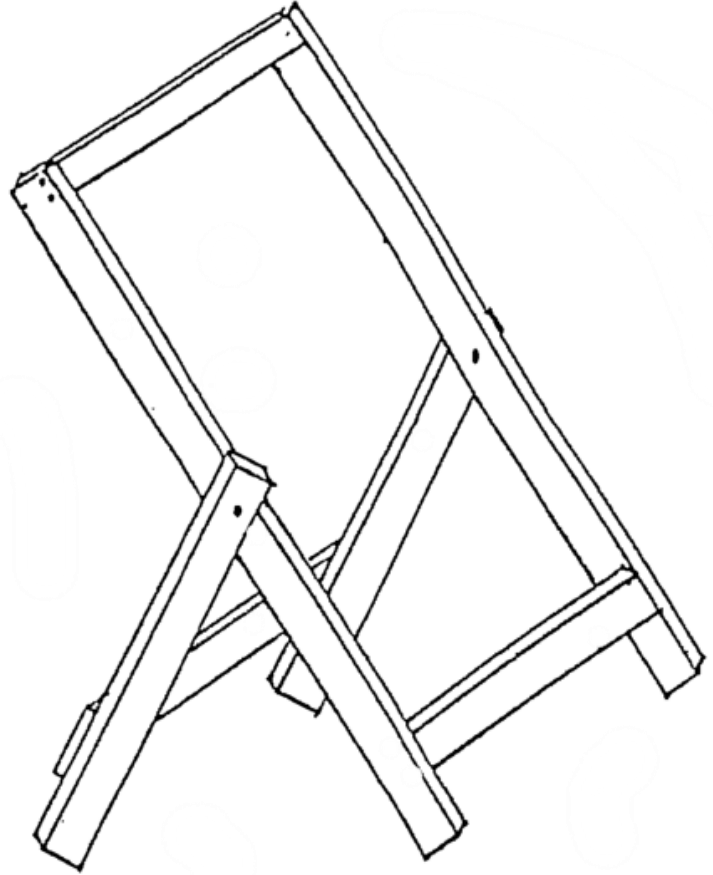

HINTS FOR SIGHT ALIGNMENT

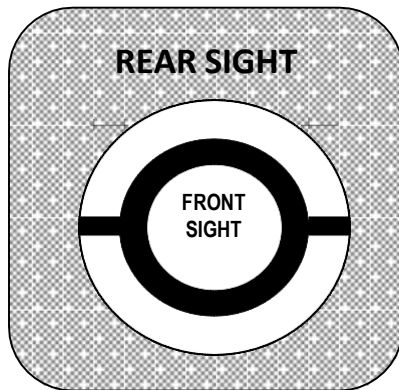

THE APERTURE IN THE FRONT SIGHT MUST BE PERFECTLY CENTERED IN THE REAR APERTURE

PROPER SIGHT ALIGNMENT IS VERY DIFFICULT IF YOUR AIMING EYE IS THE WRONG DISTANCE FROM THE REAR SIGHT. THIS IS CALLED EYE RELIEF.

EYE RELIEF SHOULD BE ABOUT 3 INCHES WHEN YOU ARE IN POSITION. IF YOU ARE CLOSER, THE REAR APERTURE WILL LOOK TOO BIG AND YOU WON'T BE ABLE TO CENTER THE FRONT APERTURE EASILY. IF YOU ARE TOO MUCH FARTHER FROM THE SIGHT, THE FRONT APERTURE WILL LOOK TOO BIG MAKING GOOD SIGHT ALIGNMENT VERY HARD TO DO.

YOUR HEAD POSITION MUST STAY THE SAME FOR EACH SHOT. YOU HAVE TO FIND THE RIGHT PLACE FOR YOUR HEAD SO THAT THE REAR APERTURE IS A FULL CIRCLE. IF YOUR EYE ISN'T LINED UP WITH THE REAR SIGHT THE HOLE IN THE SIGHT WILL HAVE A SQUARE SIDE. IF YOU DON'T SEE A PERFECT REAR CIRCLE TELL YOUR COACH SO THAT SOME ADJUSTMENT CAN BE MADE.

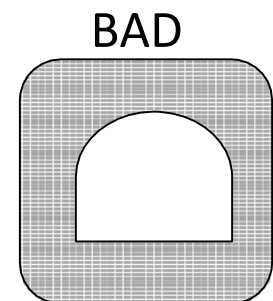
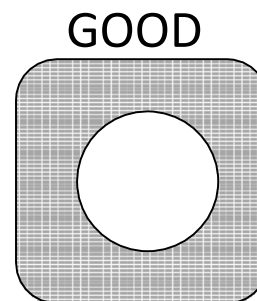
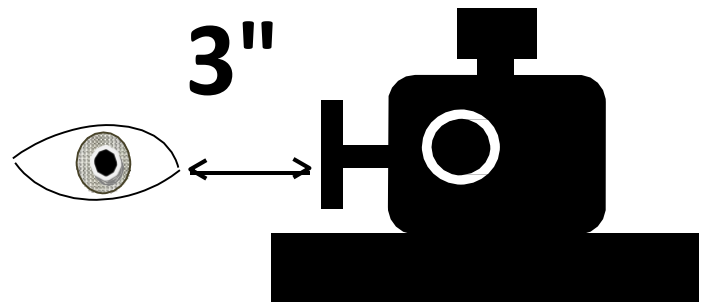

*ALWAYS USE AN EYE BLOCK FOR YOUR NON AIMING EYE EITHER ON THE REAR SIGHT OR ON YOUR FACE
ALWAYS, ALWAYS, ALWAYS AIM WITH BOTH EYES OPEN*

PROPER USE OF THE EYES IN AIMING

The eye and sight system involves proper use of the eyes, selection and use of the sight system. It is not necessary to have natural 20/20 vision. Many national and world champions use corrective lenses. It is important to have corrected vision of approximately 20/20 allowing the shooter to see the sight picture clearly. An ophthalmologist should provide a thorough examination and accurate vision correction.

There are several rules that should be kept in mind regarding the use of the eyes in sighting:

1. Look straight forward from the eye sockets. Eyes see most accurately when looking straight forward. Eye muscle tension and strain are avoided.
2. Shoot with both "eyes open. If one eye is closed the muscles of that eye will fatigue and result in an annoying disruption of shooter concentration. The non-aiming eye should not be placed in darkness by covering it with a patch or similar device. The eyes work as a team and if one eye is placed in darkness the pupil of that eye will tend to enlarge. The pupil of the aiming eye will also enlarge somewhat in sympathy with the non-aiming eye. The result is a less than optimally clear sight picture.
3. A blinder or vision blocking device is recommended to help avoid squinting and eye fatigue. The blinder may be of any suitable semi-flexible material of a translucent or neutral color. Use of a line of sight blocking device for the non-aiming eye will also reduce distractions therefore enhancing concentration.
4. Almost everyone's eyes differ somewhat. Eyes differ as widely as individual hands. Eyes vary in their acuity, depth perception, ability to see colors, reactions to bright and dim light, etc. With this in mind each shooter must select his own sight system and aperture settings to see optimally.

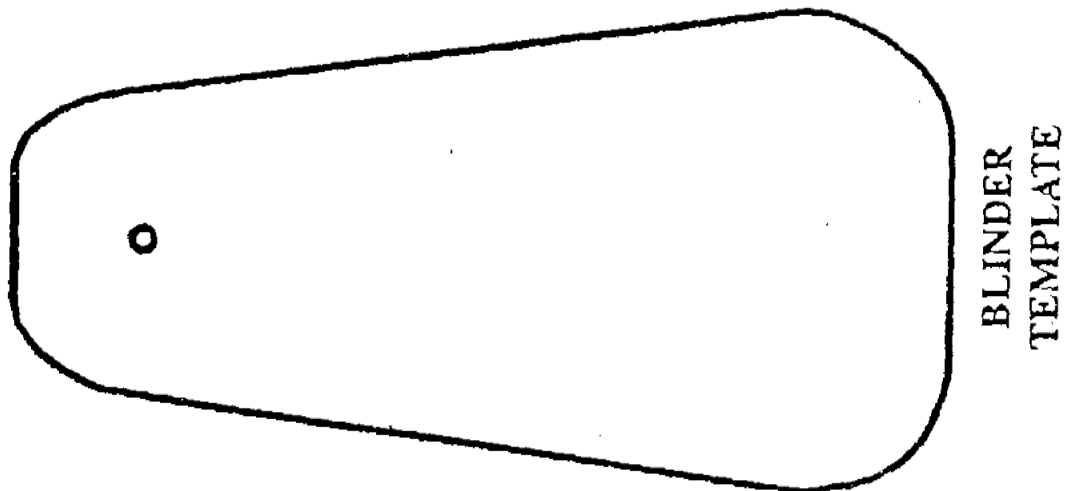

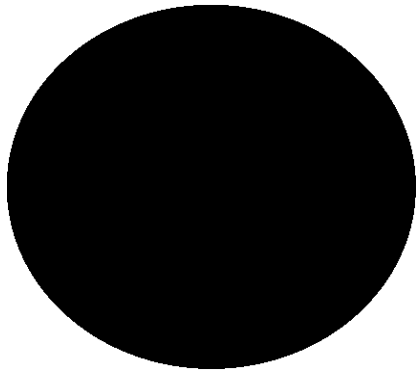

TARGET

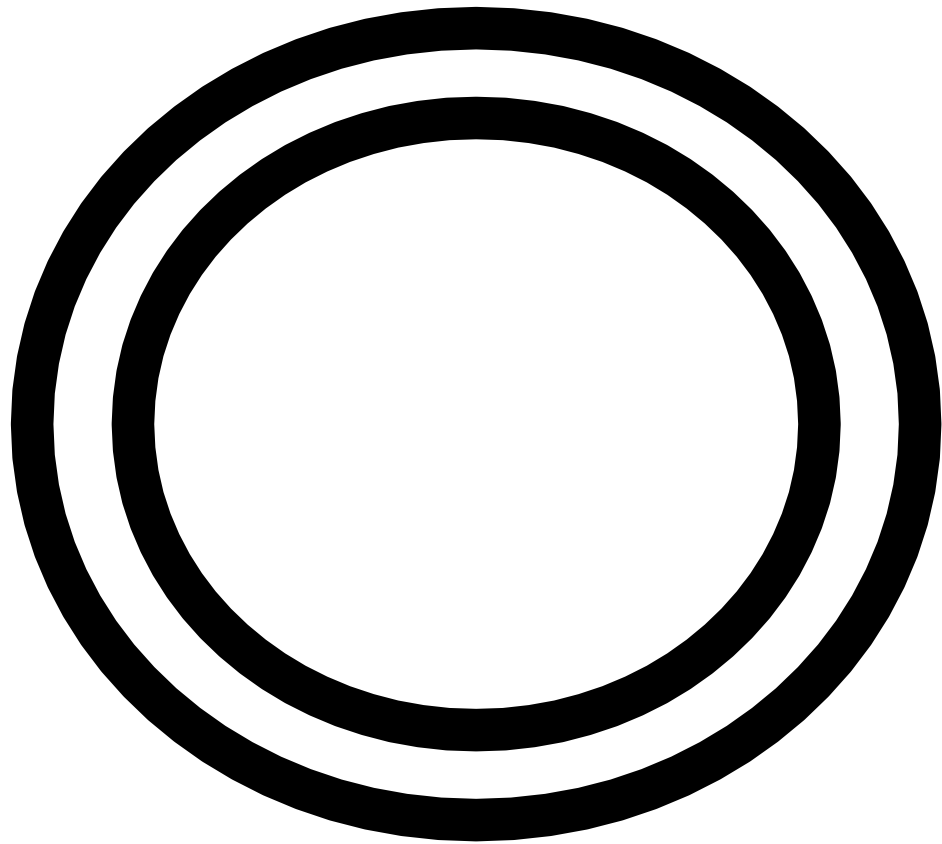

FRONT SIGHT

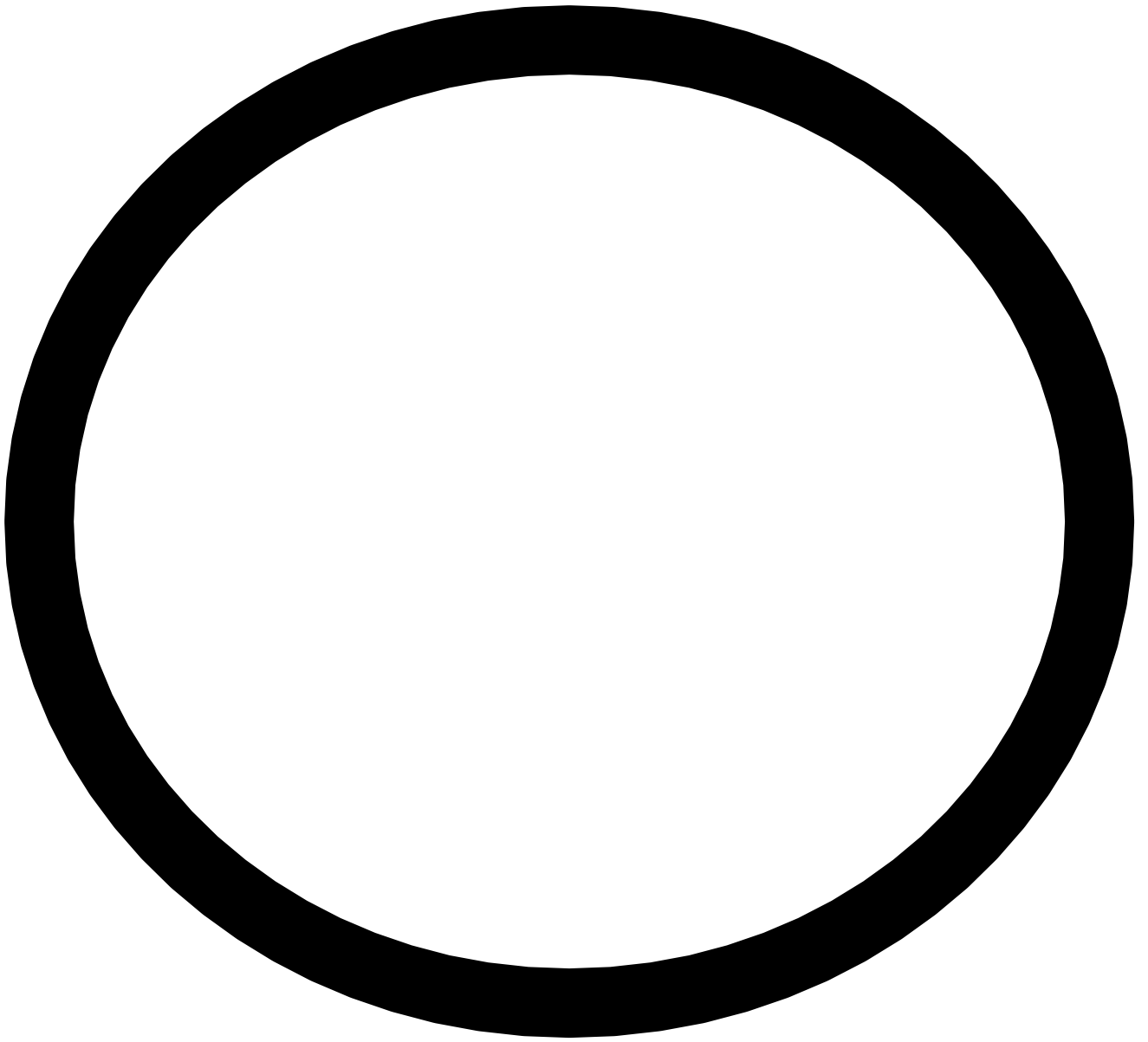

REAR SIGHT

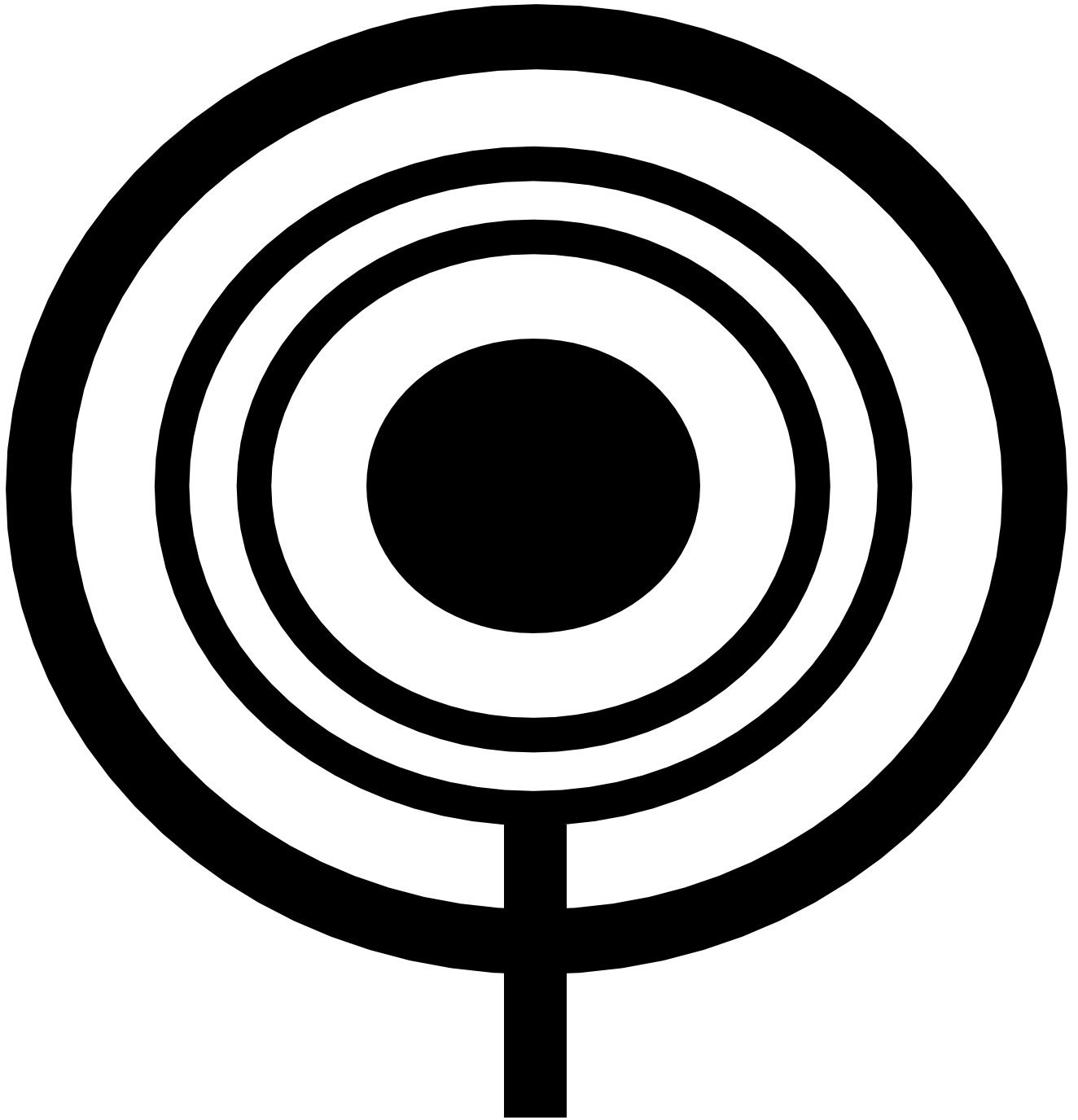

TARGET

HOW TO USE TARGET SIGHTS

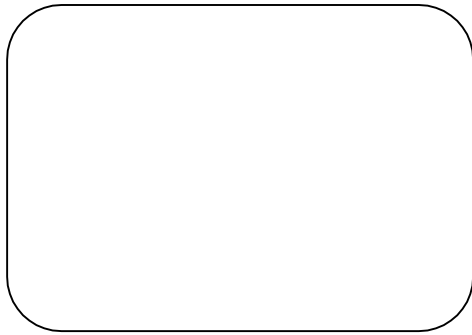

THIS IS WHAT YOU SEE WHEN YOU LOOK AT A BLANK WALL!

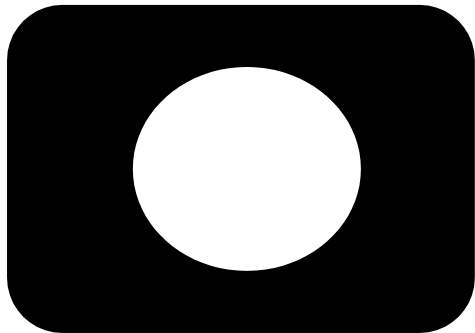

THIS IS WHAT YOU SEE WHEN YOU LOOK AT A BLANK WALL THROUGH YOUR REAR SIGHT

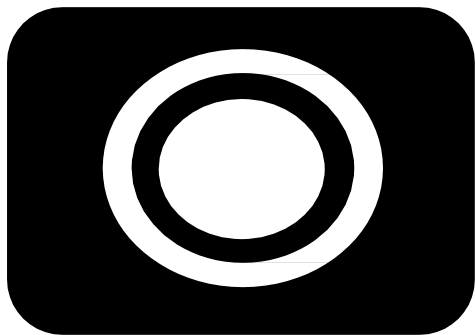

WHEN YOU LINE UP YOUR FRONT SIGHT IN THE CENTER OF YOUR REAR SIGHT IT LOOKS LIKE THIS

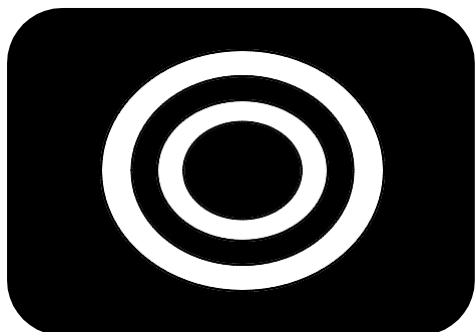

WHEN YOU PUT A TARGET ON THE BLANK WALL AND CENTER THE FRONT AND REAR SIGHT SO IT LOOKS LIKE THIS. YOU HAVE A PERFECT SIGHT PICTURE

SIGHT ALIGNMENT LESSON

GET A LONG CARDBOARD TUBE, LIKE OUT OF A ROLL OF PAPER TOWELS (THE LONGER THE BETTER)

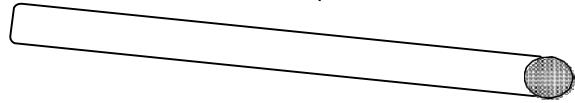

HOLD THE TUBE IN FRONT OF YOUR EYE AND LOOK THROUGH IT AT A DISTANT OBJECT.



MOVE THE TUBE AND YOUR BODY AROUND WHILE KEEPING THE OBJECT IN VIEW.

IT SHOULD BE VERY EASY TO KEEP THE TUBE LINED UP ON YOUR OBJECT!

NOW MOVE ONE END OF THE TUBE WITHOUT MOVING THE OTHER.

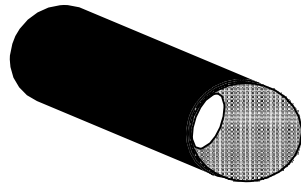

WITH THE TUBE CROOKED TO YOUR EYE, IT IS IMPOSSIBLE TO SEE YOUR OBJECT!

THE FRONT AND REAR APERTURE SIGHTS ON YOUR RIFLE ARE LIKE THE ENDS OF A TUBE. IF THEY ARE NOT IN LINE IT IS *IMPOSSIBLE TO HIT THE TARGET!!!* (APERTURE IS JUST A BIG WORD FOR HOLE)

YOU CAN PRACTICE SIGHT ALIGNMENT BY AIMING AT A BLANK WALL.

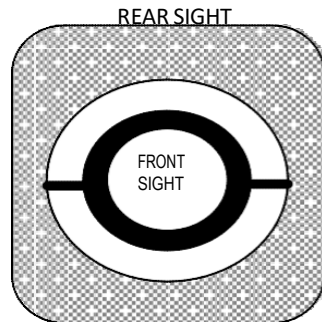

HINTS FOR SIGHT ALIGNMENT

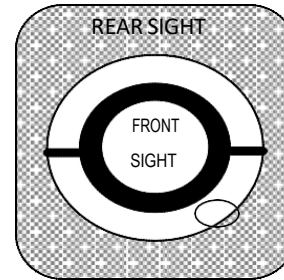

THE APERTURE IN THE FRONT SIGHT MUST BE PERFECTLY CENTERED IN THE REAR APERTURE.

PROPER SIGHT ALIGNMENT IS VERY DIFFICULT IF YOUR AIMING EYE IS THE WRONG DISTANCE FROM THE REAR SIGHT. THIS IS CALLED EYE RELIEF.

EYE RELIEF SHOULD BE ABOUT 3 INCHES WHEN YOU ARE IN POSITION. IF YOU ARE CLOSER, THE REAR APERTURE WILL LOOK TOO BIG AND YOU WON'T BE ABLE TO CENTER THE FRONT APERTURE EASILY. IF YOU ARE TOO MUCH FARTHER FROM THE SIGHT, THE FRONT APERTURE WILL LOOK TOO BIG MAKING GOOD SIGHT ALIGNMENT VERY HARD TO DO.

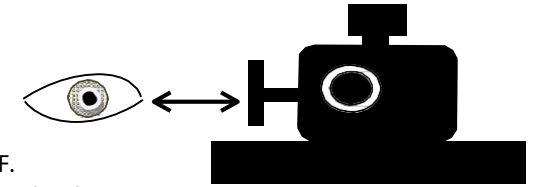

YOUR HEAD POSITION MUST STAY THE SAME FOR EACH SHOT. YOU HAVE TO FIND THE RIGHT PLACE FOR YOUR HEAD

SO THAT THE REAR APERTURE IS A FULL CIRCLE. IF YOUR EYE ISN'T LINED UP WITH THE REAR SIGHT THE HOLE IN THE SIGHT WILL HAVE A SQUARE SIDE. IF YOU DON'T SEE A PERFECT REAR CIRCLE TELL YOUR COACH SO THAT SOME ADJUSTMENT CAN BE MADE.

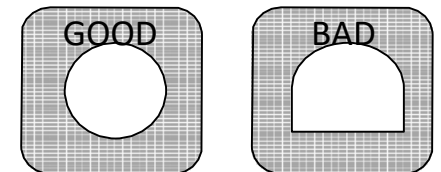
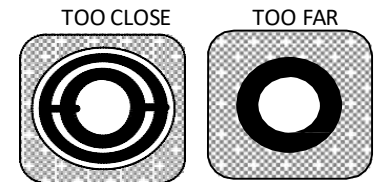

ALWAYS USE AN EYE BLOCK FOR YOUR NON-AIMING EYE, EVEN WITH A SCOPE. (IT CAN BE ATTACHED TO EITHER THE SIGHT OR YOUR FACE.)

ALWAYS, ALWAYS, ALWAYS AIM WITH BOTH EYES OPEN

SIGHT ALIGNMENT APERTURE SIGHT

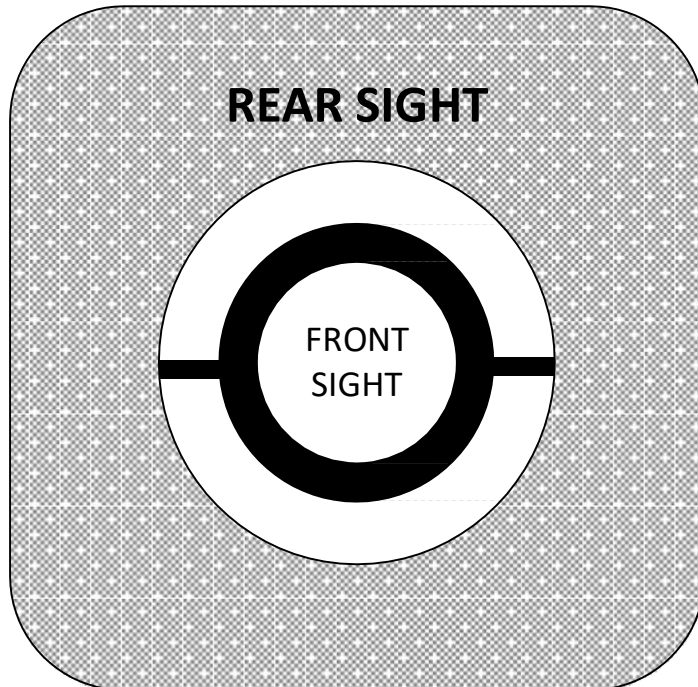

SIGHT ALIGNMENT DOES NOT INCLUDE THE TARGET. IT IS HOW THE FRONT AND REAR SIGHT LINE UP WITH YOUR EYE. THE CIRCLE OF THE FRONT SIGHT (APERTURE) SHOULD BE EXACTLY IN THE MIDDLE OF THE HOLE (APERTURE) IN THE REAR SIGHT. YOU CAN EASILY PRACTICE YOUR SIGHT ALIGNMENT AT HOME WITH A BLANK WALL.

SIGHT ALIGNMENT POST SIGHT

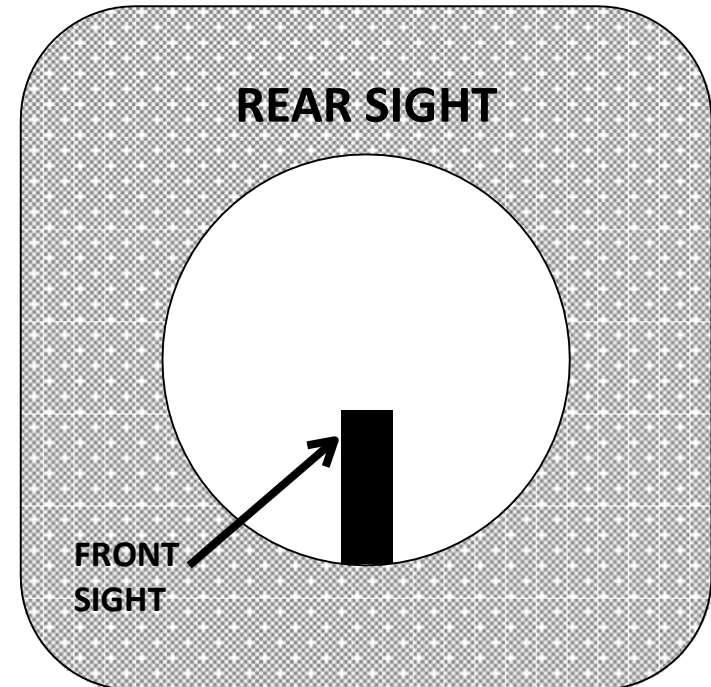

SIGHT ALIGNMENT DOES NOT INCLUDE THE TARGET. IT IS HOW THE FRONT AND REAR SIGHT LINE UP WITH YOUR EYE. THE POST OF THE FRONT SIGHT SHOULD BE EXACTLY IN THE MIDDLE OF THE HOLE (APERTURE) IN THE REAR SIGHT. YOU CAN PRACTICE AT HOME WITH A BLANK WALL.

THE IMPORTANCE OF SIGHT ALIGNMENT

Proper sight alignment is the key to accurate shooting. Any misalignment of the front sight with the rear sight introduces an angular error that is multiplied with distance.

The formula is:

$$\frac{DT}{S_L}$$

Where:

DT = DISTANCE TO TARGET (IN INCHES)

SR = SIGHT RADIUS (DISTANCE BETWEEN FRONT AND REAR SIGHT)

AE = ALIGNMENT ERROR (OF FRONT SIGHT, IN INCHES)

PI = POINT OF IMPACT OF BULLET (INCHES FROM CENTER OF BULLSEYE)

For example, if the distance to the target is 50 ft. (600 inches), the sight radius is 31 inches, and the alignment error is .05 inch to the right, then the point of bullet impact can be calculated as follows: (This formula may also be used to calculate the potential advantage of a longer barrel or bloop tube).

$$\frac{600}{31} \times .05 = .97$$

This misaligned shot would hit almost 1 inch to the right of the center of the bullseye.

MISALIGNMENT RESULTS

A-36 BULL

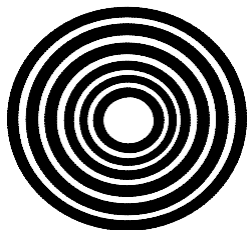

CENTER SHOT WHEN SIGHTS ARE CORRECTLY ALIGNED

A-36 BULL

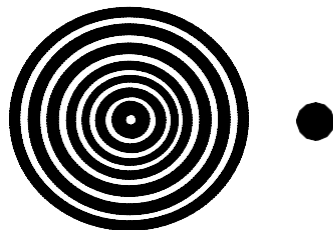

.97 INCH TO THE RIGHT OF CENTER WHEN SIGHTS ARE MISALIGNED ONLY .05 OF AN INCH

SIGHT PICTURE WITH SIGHT ALIGNMENT PROBLEMS

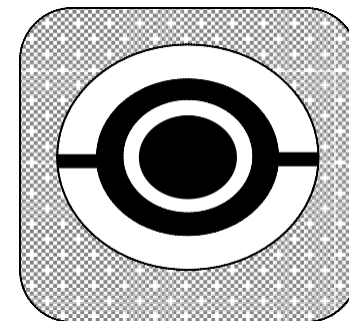
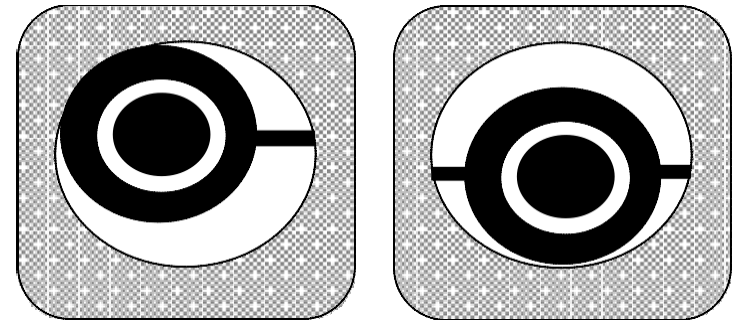
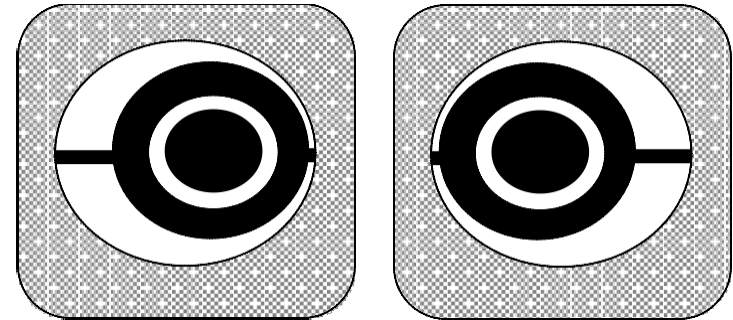

SIGHT ALIGNMENT NEEDS YOUR EYE AND THE FRONT AND REAR APERTURES IN LINE. EVEN IF THE BULL IS IN THE CENTER OF THE FRONT SIGHT, THE SHOT WILL BE OFF IF SIGHT ALIGNMENT IS NOT PERFECT.

SIGHT PICTURE

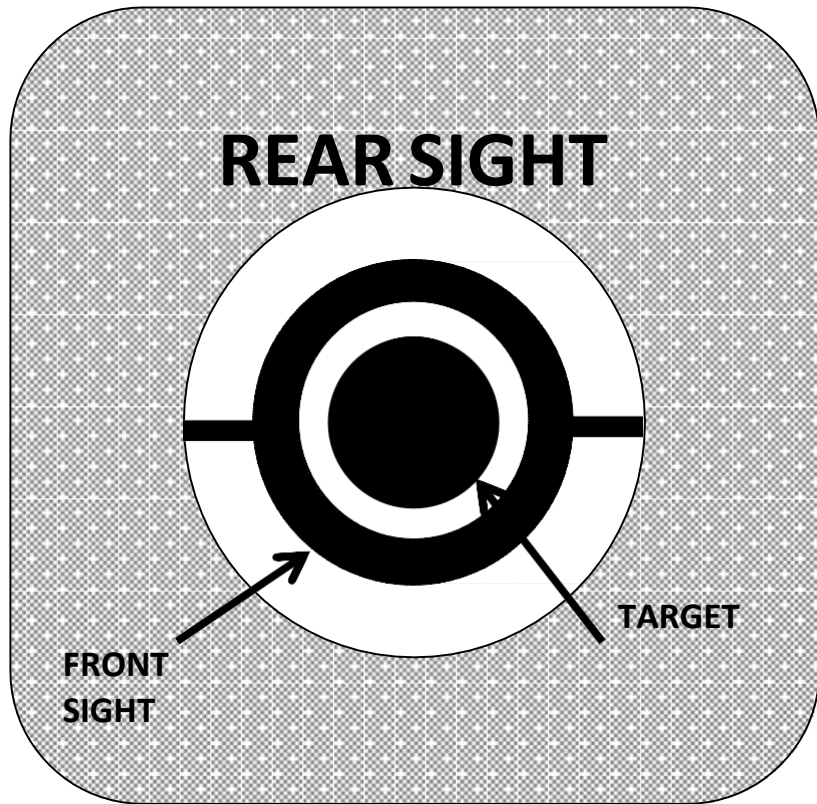

WHEN YOUR SIGHT ALIGNMENT IS GOOD AND YOU ADD THE TARGET TO THE MIDDLE YOU HAVE THE SIGHT PICTURE. IF THE SIGHT ALIGNMENT ISN'T PERFECT OR IF THE TARGET ISN'T IN THE CENTER, YOUR SHOT WON'T GO WHERE YOU WANT.

PERFECT SIGHT PICTURE

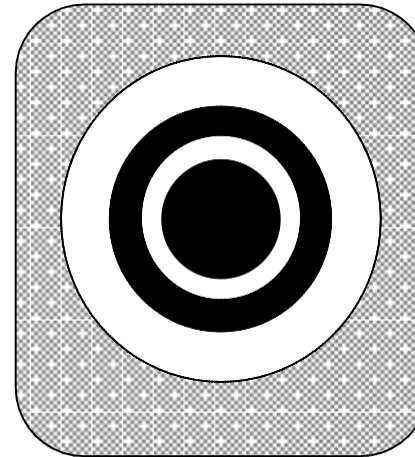

IF YOU LINE UP THE SIGHTS AND TARGET LIKE THIS WHEN THE SHOT IS FIRED YOU WILL SHOOT A 10

(if the sights are adjusted)

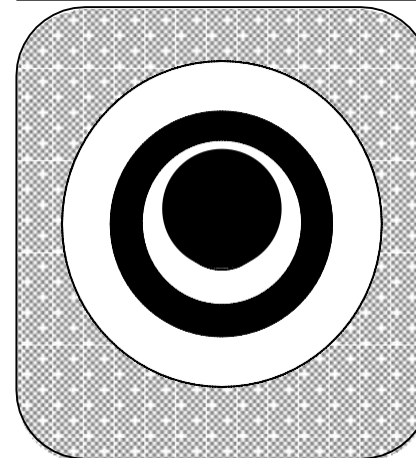

NOT PERFECT SIGHT PICTURE

SIGHT ALIGNMENT

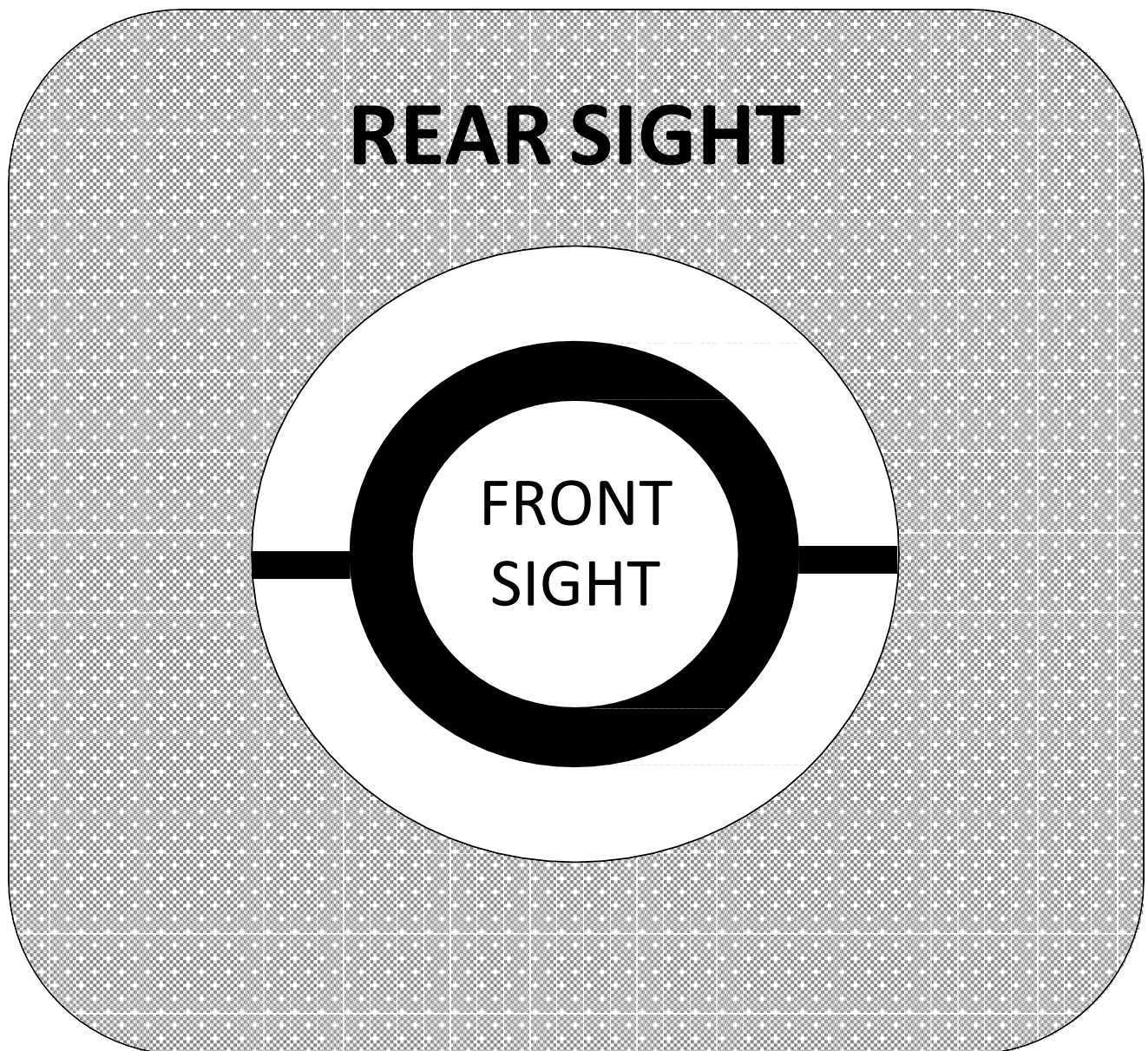

SIGHT ALIGNMENT DOES NOT INCLUDE THE TARGET. IT IS HOW THE FRONT AND REAR SIGHT LINE UP WITH YOUR EYE. THE CIRCLE OF THE FRONT SIGHT (APERTURE) SHOULD BE EXACTLY IN THE MIDDLE OF THE HOLE (APERTURE) IN THE REAR SIGHT.

SIGHT ALIGNMENT

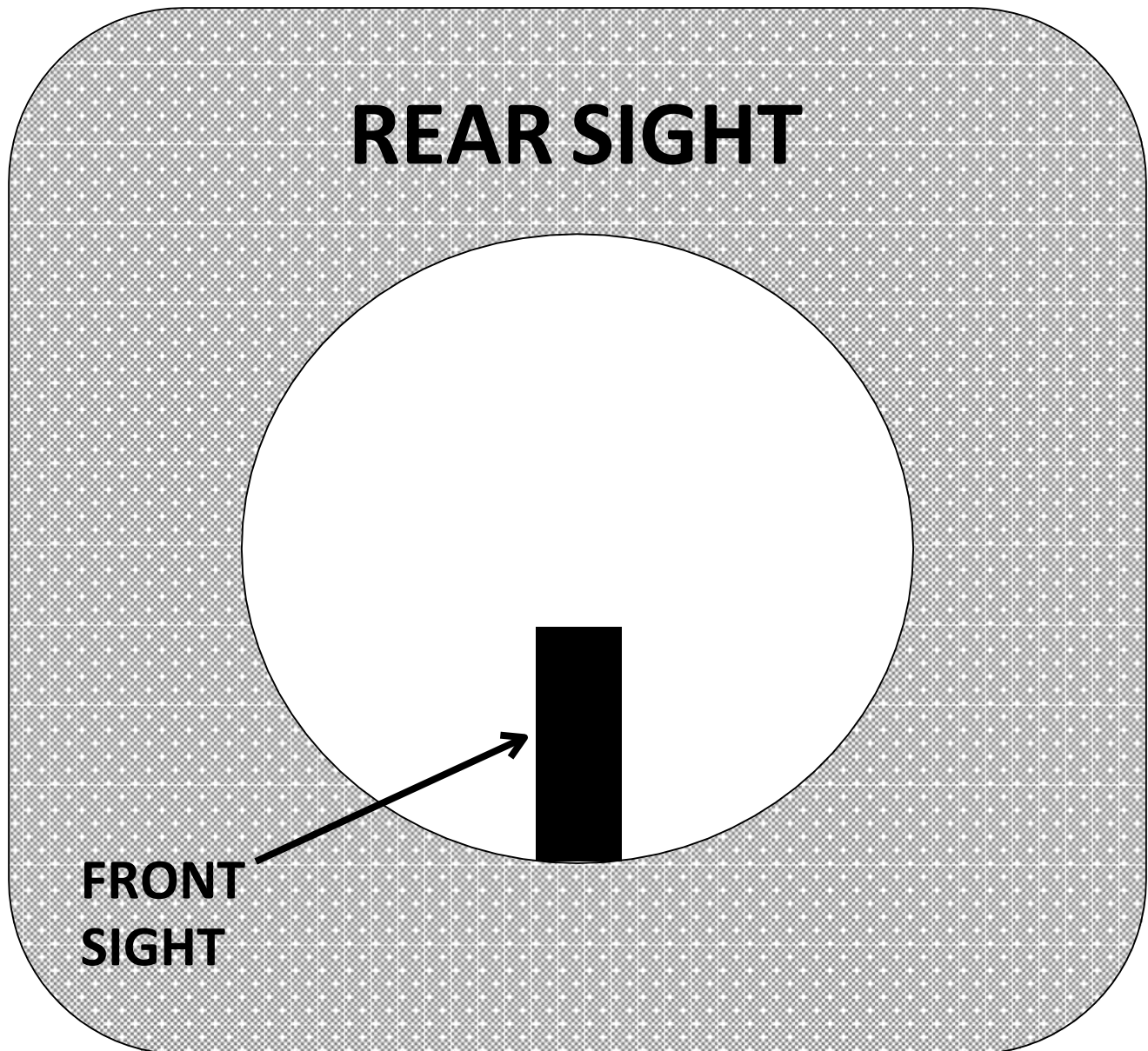

SIGHT ALIGNMENT DOES NOT INCLUDE THE TARGET. IT IS HOW THE FRONT AND REAR SIGHT LINE UP WITH YOUR EYE. THE POST OF THE FRONT SIGHT SHOULD BE EXACTLY IN THE MIDDLE OF THE HOLE (APERTURE) IN THE REAR SIGHT.

SIGHT PICTURE

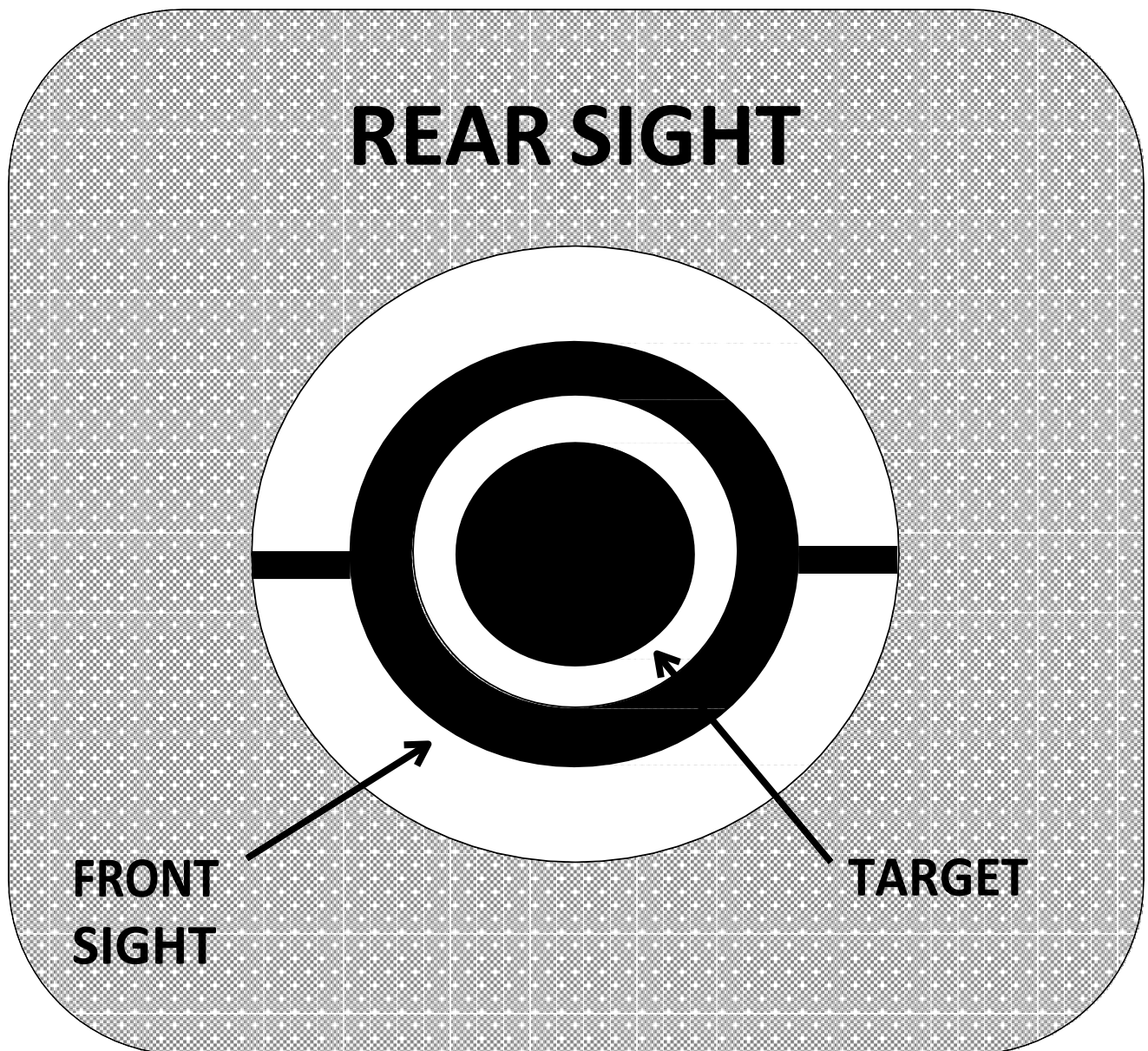

WHEN YOUR SIGHT ALIGNMENT IS GOOD AND YOU ADD THE TARGET TO THE MIDDLE YOU HAVE THE SIGHT PICTURE. IF THE SIGHT ALIGNMENT ISN'T PERFECT OR IF THE TARGET ISN'T IN THE CENTER, YOUR SHOT WON'T GO WHERE YOU WANT.

SIGHT PICTURE

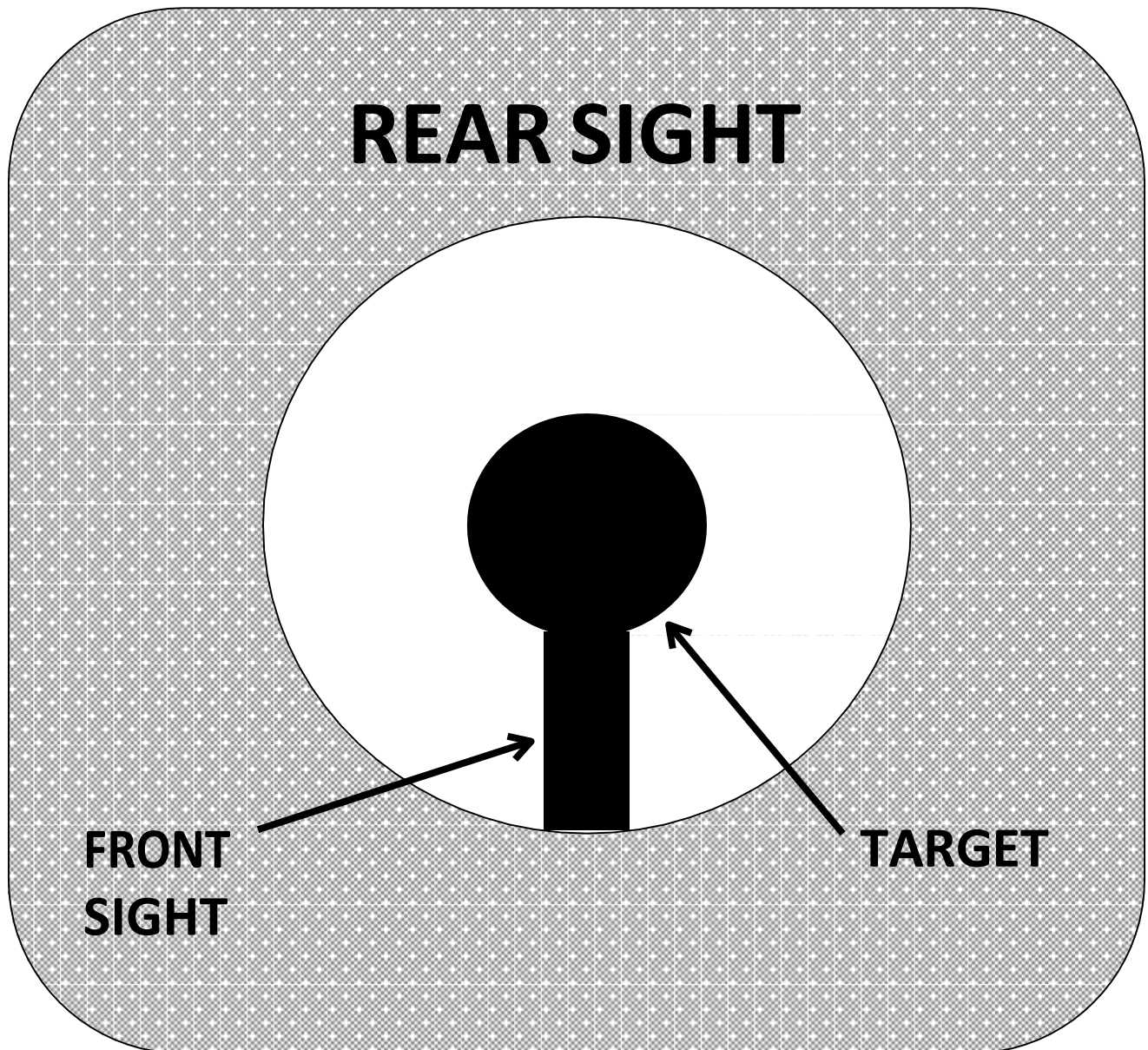

WHEN YOUR SIGHT ALIGNMENT IS GOOD AND YOU ADD THE TARGET TO THE MIDDLE YOU HAVE THE SIGHT PICTURE. THE TARGET SHOULD SIT JUST ON TOP OF THE POST.

PERFECT SIGHT PICTURE

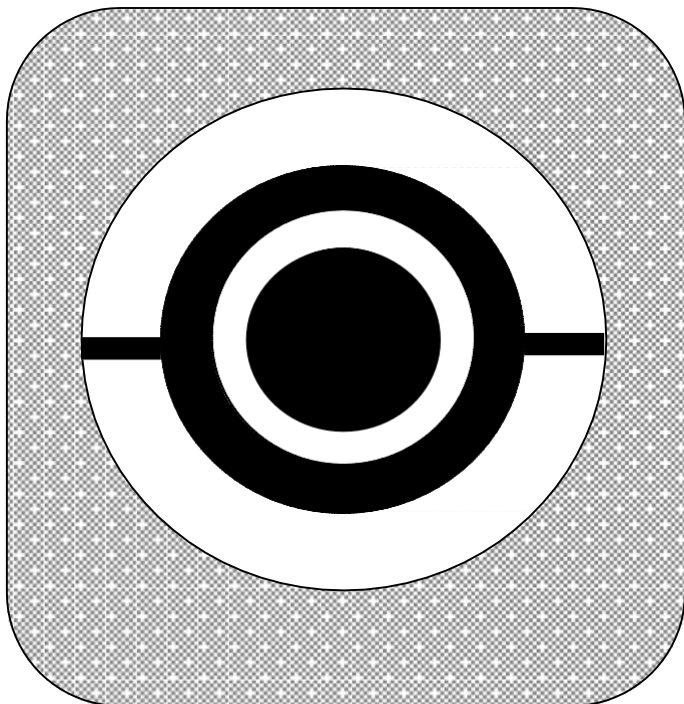

A PERFECT SIGHT PICTURE NEEDS PERFECT SIGHT ALIGNMENT AND THE TARGET IN THE RIGHT PLACE.

IF YOU LINE UP THE SIGHTS AND TARGET LIKE THIS WHEN THE SHOT IS FIRED YOU WILL SHOOT A 10 (if the sights are adjusted)

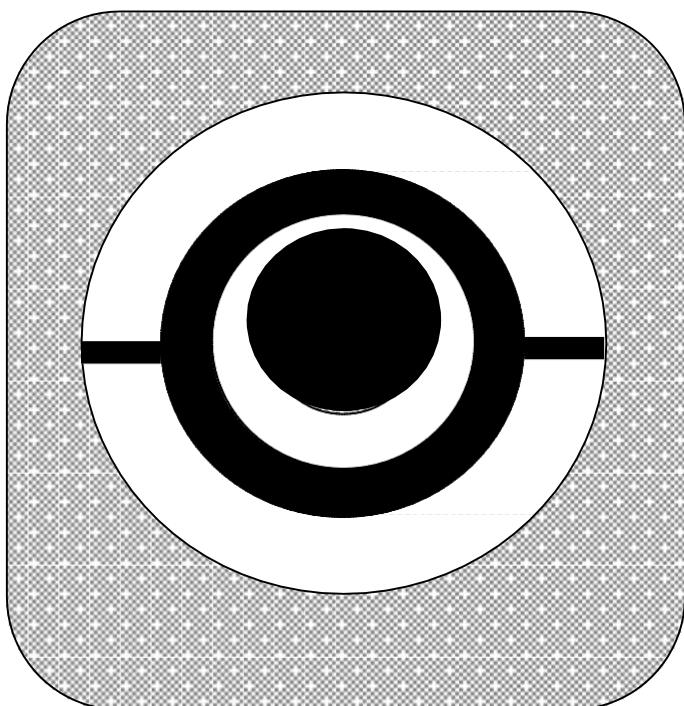

IF THE SIGHTS AND TARGET ARE LINED UP LIKE THIS WHEN THE SHOT IS FIRED THE SHOT WILL GO LOW

NOT PERFECT SIGHT PICTURE

PERFECT SIGHT PICTURE

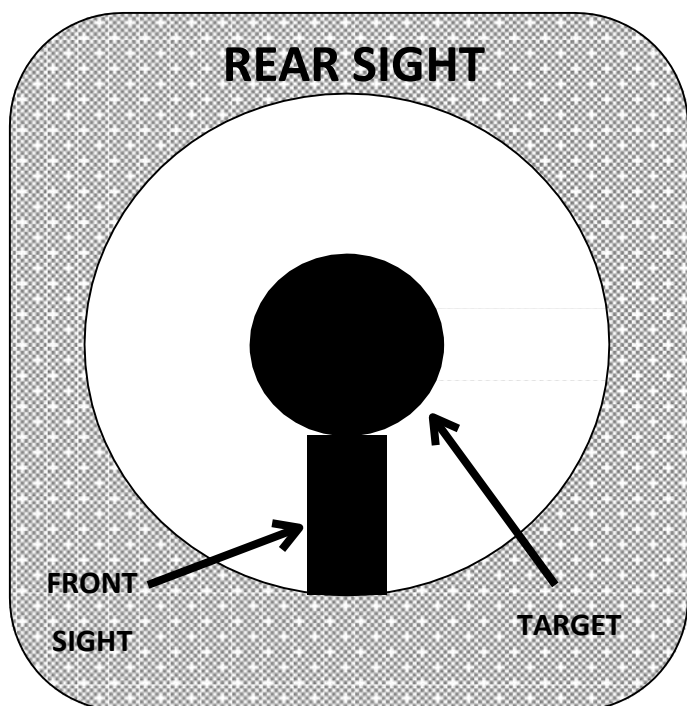

A PERFECT SIGHT PICTURE HAS PERFECT SIGHT ALIGNMENT AND THE TARGET ADDED IN THE RIGHT PLACE.

IF YOU LINE UP THE SIGHTS AND TARGET LIKE THIS WHEN THE SHOT IS FIRED YOU WILL SHOOT A 10 (if the sights are adjusted)

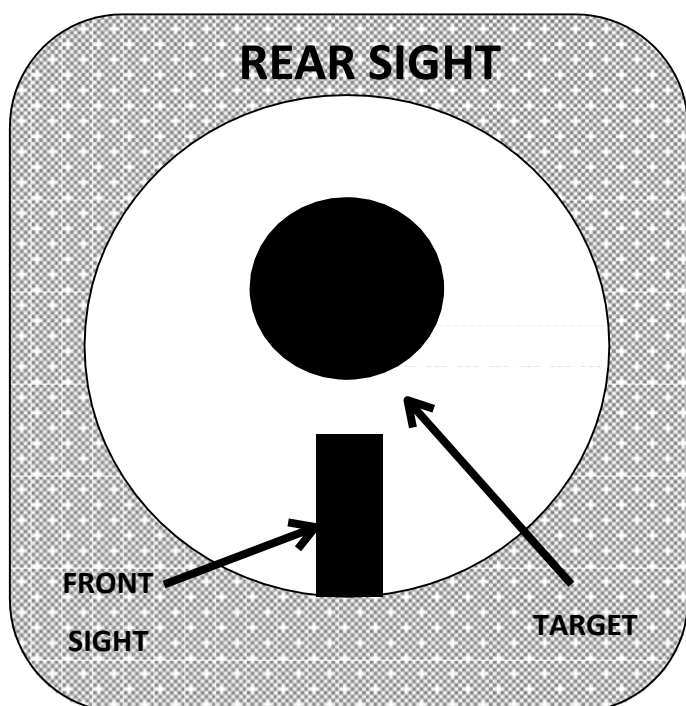

IF THE SIGHTS AND TARGET ARE LINED UP LIKE THIS WHEN THE SHOT IS FIRED THE SHOT WILL GO LOW

NOT PERFECT SIGHT PICTURE

**A PERFECT SIGHT PICTURE MUST
HAVE PERFECT SIGHT ALIGNMENT
AND A TARGET IN THE CENTER.**

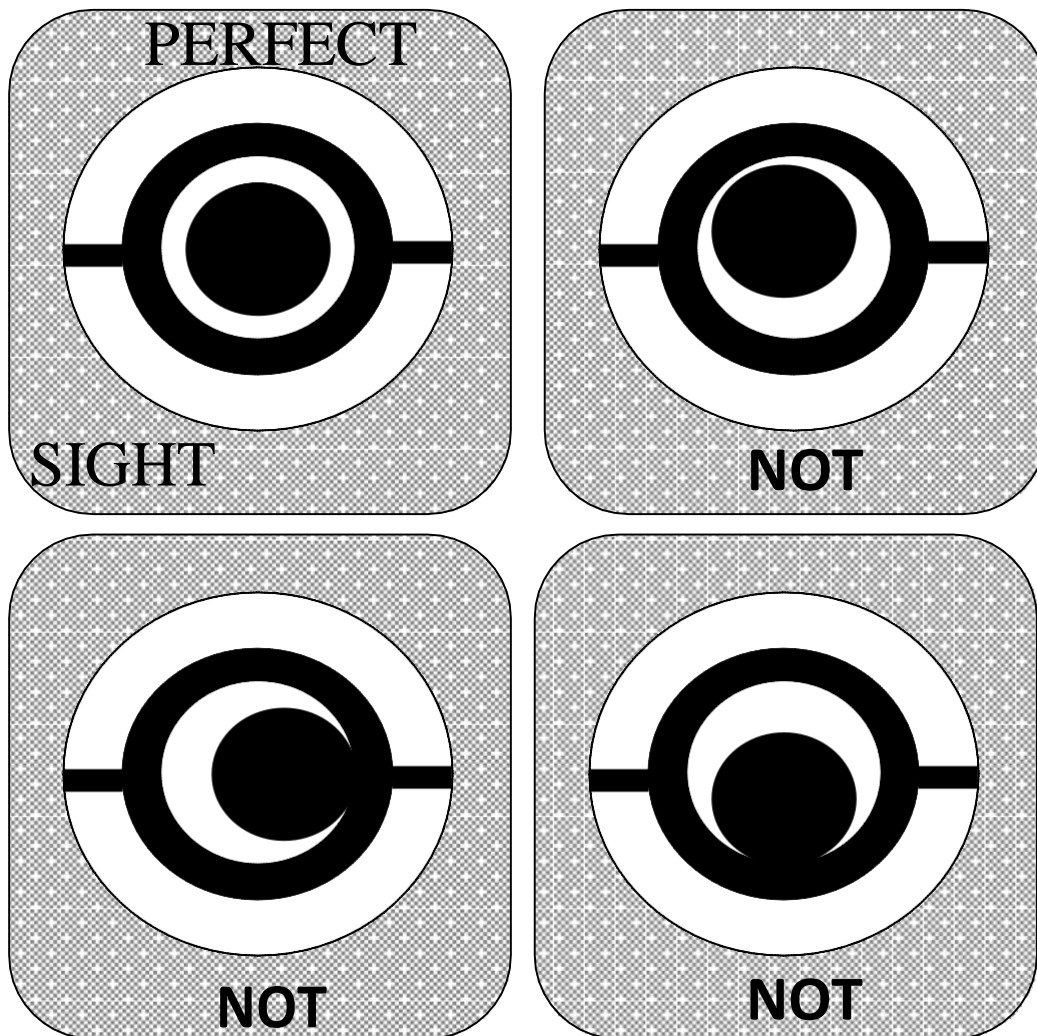

**YOU CANNOT GET A PERFECT
SIGHT PICTURE IF YOU ARE
LOOKING AT THE TARGET.
YOU MUST FOCUS ON THE FRONT SIGHT! YOUR
EYE CANNOT SEE BOTH THE TARGET AND THE
FRONT SIGHT CLEARLY!**

SIGHT PICTURE WITH SIGHT ALIGNMENT PROBLEMS

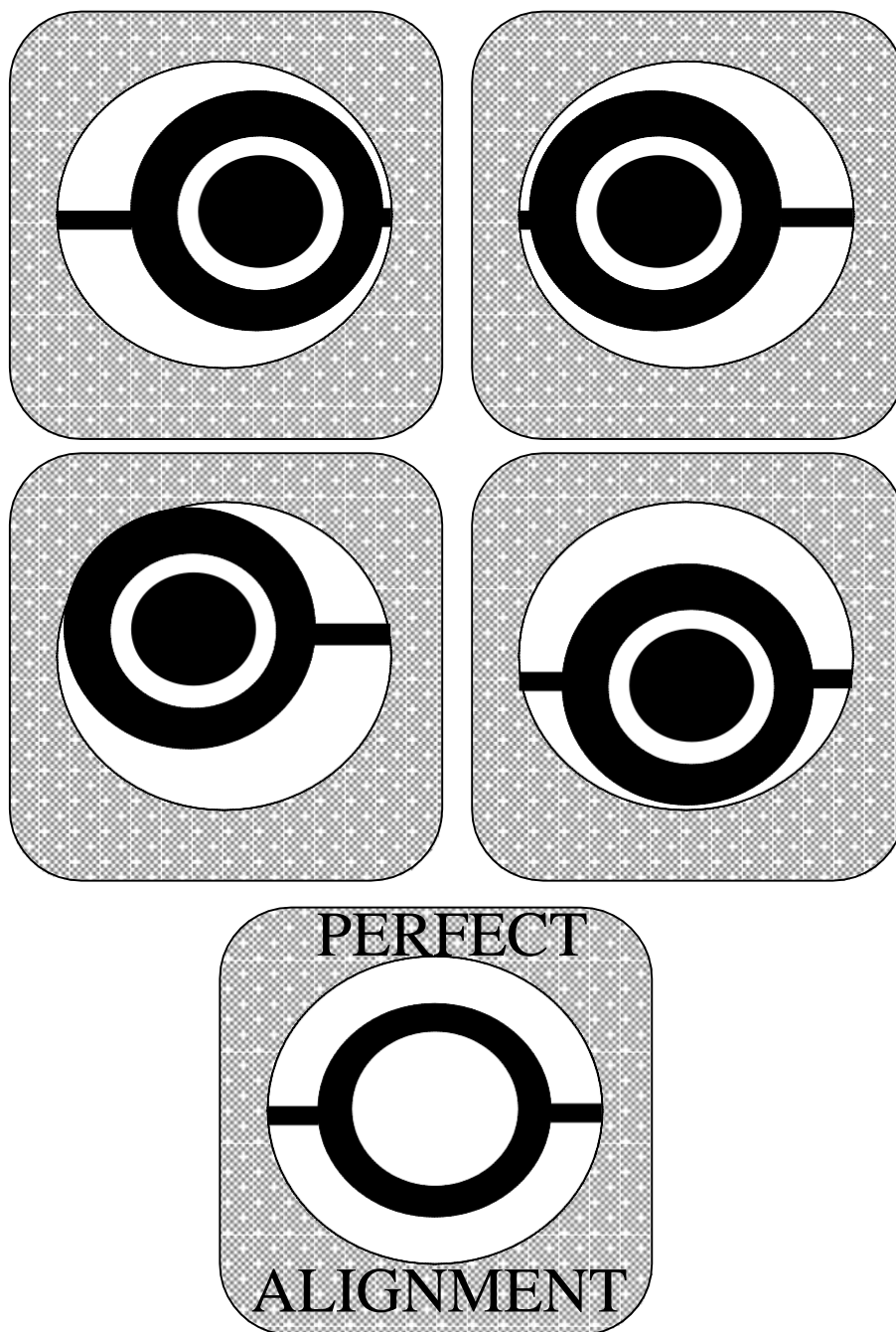

REMEMBER THAT SIGHT ALIGNMENT IS HOW YOUR EYE LINES UP WITH THE FRONT AND REAR SIGHT. EVEN IF THE TARGET IS IN THE MIDDLE OF THE FRONT SIGHT, BAD SIGHT ALIGNMENT WILL THROW THE SHOT OFF.

FUNDAMENTALS OF THE SHOT

1. AIMING
2. BREATH CONTROL
3. HOLD CONTROL
4. TRIGGER CONTROL
5. FOLLOW THROUGH

AIMING - Sight alignment is the relationship between the front and rear sight. With an aperture front sight, by aligning the front aperture in the exact center of the rear aperture, you have a proper sight picture. Consistent sight alignment is a little more difficult with a front post but must be the same for each shot for proper aiming. Sight picture is when you add the target to the sight alignment. Perfect sight alignment occurs when the target is centered in the front and rear sights. It is not necessary to hold the gun perfectly still to have a perfect sight picture. If you were looking through a long tube, you could keep a distant object in the center while still allowing the tube to move quite a bit as long as you don't let the tube get at an angle to the object. This is keeping perfect sight alignment while maintaining the sight picture. Keep both eyes open while aiming. Use an eye block if necessary. Don't try to aim too long. Take a break if you have to.

BREATH CONTROL - If you try to thread a needle or any other task requiring concentration, you will naturally hold your breath while doing it. The same thing happens when you aim a rifle. The need for breath control is not holding your breath too long. If you hold your breath longer than 8-10 seconds, you start starving your body for oxygen and the first part affected is your eyes. For most people the ideal time to get a shot off is after about six seconds.

HOLD CONTROL - NO ONE CAN HOLD A RIFLE PERFECTLY STILL!!!! Your individual ability to hold still will improve with proper position, practice, physical condition, proper nutrition, and better concentration. There is no magic formula for a good hold, just hard work and doing more things right. If your current level of ability is a six-ring hold, you should be happy with any shot that is at least a six. If you try to shoot at a moving target when you see the 10 ring go past you will probably shoot a 3. ACCEPT YOUR

HOLD!!! As shooters get better they often forget this principle and let their desire for 10's get in the way of steady improvement. When this happens, scores usually go, down instead of up and many times a really good shooter will give up shooting in disgust. Don't let this happen to you. Try to shoot each shot within your hold and improve, gradually.

TRIGGER CONTROL - Shooting a ten is easy. All you have to do is line the sights up with the target and make the gun fire without disturbing the sights. HA!! Think of trigger control as pushing a button with your finger. DO NOT SQUEEZE. This can make your whole hand move. When you have breath control, sight alignment, and hold all at their best, a steady increase of pressure on the trigger will cause the gun to go off within your hold. Trying to consciously make the gun go off at a particular time is a jerk and will pull your shot out of where' you deserve it to be. With practice, all four of these elements will happen within six or seven seconds of when you start the shot.

FOLLOW THROUGH - Every shooter is told from the very beginning to follow through. OK, so WHAT IS FOLLOW THROUGH? Don't move. If you could not move you would be either in the Olympics or dead. FOLLOW THROUGH IS MORE MENTAL THAN PHYSICAL. You must maintain your concentration on the aiming, hold, trigger, and breath after the shot has left the barrel. If you don't, your sub-conscious mind will shut down your concentration before the shot and the shot won't go where you wanted it to. For a physical trick, try to remember to not move your aiming eyeball when the shot breaks. If the eye doesn't move, nothing else will.

STEPS TO THE GOOD SHOT:

1. SIGHT ALIGNMENT
2. SIGHT PICTURE
3. NATURAL POINT OF AIM
4. BREATH CONTROL
5. HOLD CONTROL
6. TRIGGER CONTROL
7. FIRE THE SHOT
8. FOLLOW THROUGH

STEPS TO THE GOOD SHOT:

1. SIGHT ALIGNMENT
2. SIGHT PICTURE
3. NATURAL POINT OF AIM
4. BREATH CONTROL
5. HOLD CONTROL
6. TRIGGER CONTROL
7. FIRE THE SHOT
8. FOLLOW THROUGH

Natural Point of Aim

The goal in the prone position is to be able to relax almost completely and let bone and the sling support your position. Once you have achieved that, you may not be pointing at the target. If you have to use muscle to force the gun in any direction to bring it to bear on the target, you are defeating your position. Therefore, you must move your entire body, as though it were a statue, to bring the gun into position on the target. Use the following procedure to achieve natural point of aim in prone:

- First build your position with general reference to the target. Only bone and sling should be supporting your position.

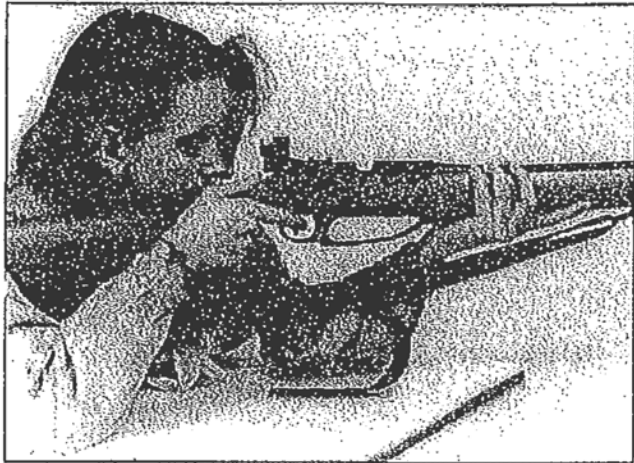

- Look through your sights, then look down and away from your sights without moving your head. Relax, let your position settle. Then look back through your sights and determine if your front sight needs to move right or left to come to bear on the target.
- Now you are going to move your body without altering your position. Using the left elbow as a pivot point, shift your body in the opposite direction that you want to move the front sight.

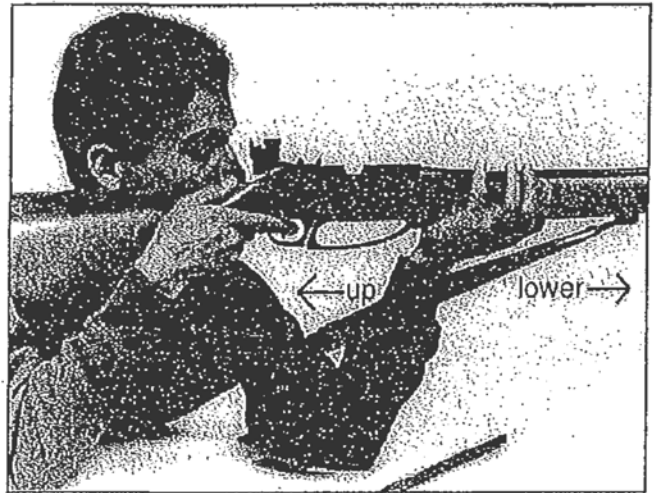

- Repeat the above steps incrementally until your sights are on a vertical line with the target.
- Getting the elevation, you need is a simple matter of moving your left hand forward on the stock to lower the front sights or moving it back to raise the front sights.
- After each adjustment, use the technique of looking through your sights, looking away and relaxing, and then looking back through your sights to find your natural point of aim. Continue making small incremental adjustments in your position to bring your sights to bear on the target.

The ultimate in natural point of aim and relaxed support would be to be able to fall asleep in your position and then to wake up and find yourself still on the target. We are still looking for the shooter who can do this!

A PERFECT BULL

7
7
8
8
9
9
9
10
+ 10
84



IF YOU HAVE A 7 RING HOLD, THIS IS WHAT 10 *PERFECT* SHOTS WILL LOOK LIKE

10s ARE A GIFT UNLESS YOU HAVE A 10 RING HOLD! YOU MUST LEARN TO BE AS HAPPY WITH A 7 AS A 10 SIGHTS MUST BE PERFECTLY ZEROED.

VERY TUFF JOB!

UNLESS YOU HAVE A 10 RING HOLD, THIS SHOULD NOT BE YOUR GOAL! IF YOU SHOOT WITHIN YOUR HOLD, YOU HAVE EXECUTED A PERFECT SHOT. AS YOU PRACTICE AND DEVELOP ASA MARKSMAN, YOUR GOAL SHOULD BE TO IMPROVE THE HOLD. IF YOU TRY TO SHOOT 10s NOW, YOU WILL SHOOT FROWNY FACE SHOTS!!!!

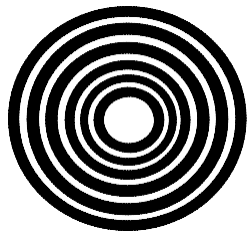

IF YOU TRY TOO HARD,
THE OVERHOLDDASURUS *WILL* GET YOU!!

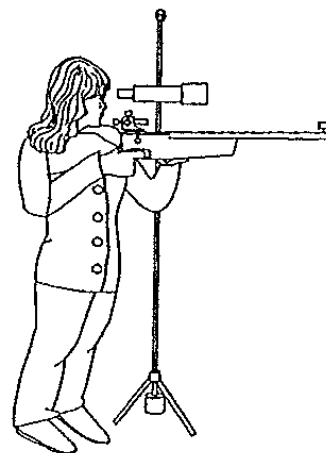
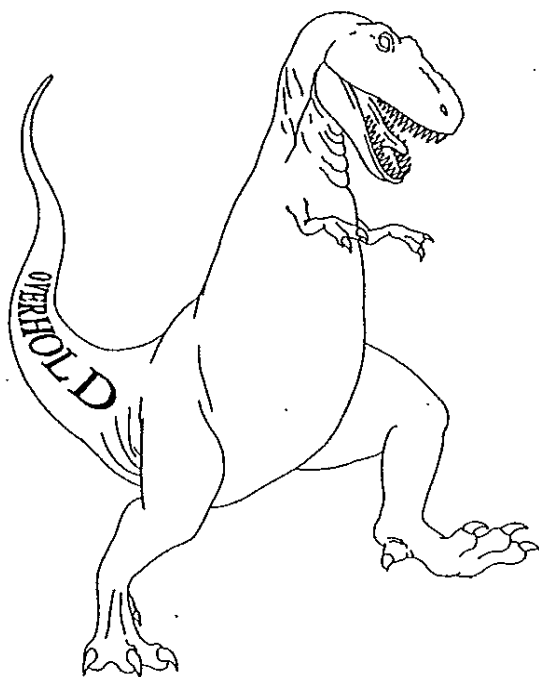

*THE ONLY WAY TO SHOOT CONSISTANTLY HIGHER SCORES IS
TO IMPROVE YOUR HOLD*



PHYSICAL CONDITIONING

FOOD – HIGH CARBOHYDRATE DIET
DRINK – NO CAFFEINE, LOTS OF WATER
EXERCISE – ENDURANCE, STRENGTH, FLEXIBILITY



TECHNIQUE

SOLID BASIC POSITION, THERE'S NO MAGIC
PRACTICE, DON'T JUST SHOOT LOTS
GIVE CHANGES A FAIR TRY – BECOACHABLE



MENTAL CONDITIONING

RELAXATION TECHNIQUES – CONTROL EMOTIONS
VISUALIZATION – MENTAL PRACTICE – SHOT PLANNING
CONCENTRATION EXERCISES AND TECHNIQUES



OK, ONE MORE TIME

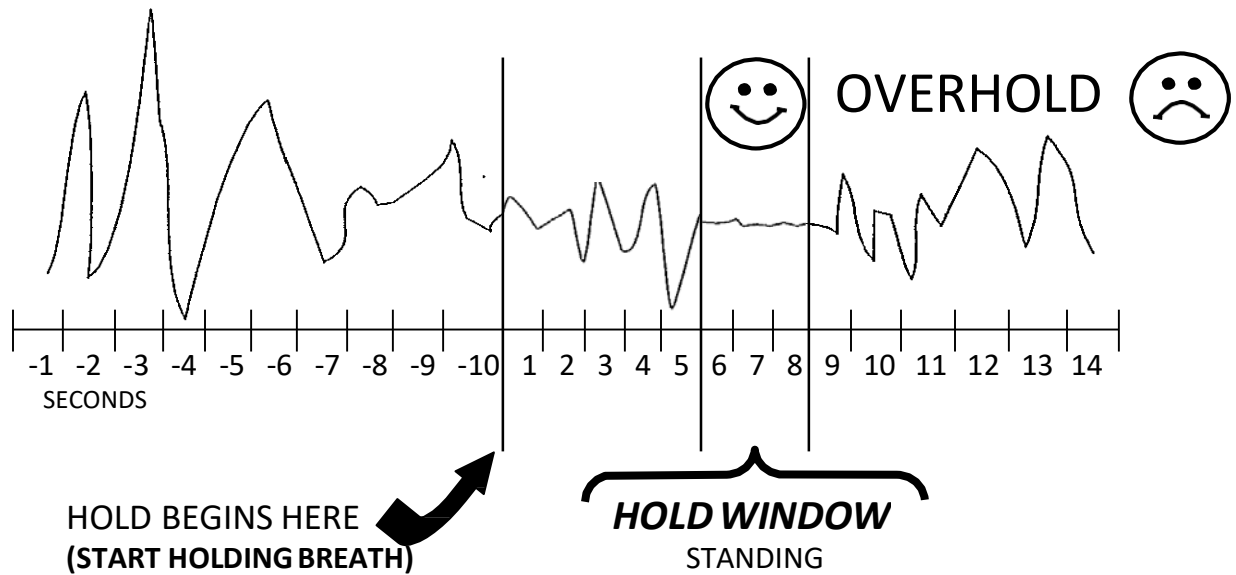

THIS IS YOUR HOLD ON SMALLBORE!



WHEN YOU HOLD FOR MORE THAN 12-15 SECONDS IN ANY POSITION, THINGS GO BAD

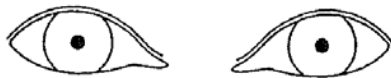

VISION REQUIRES OXYGEN

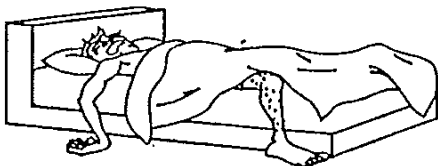

MUSCLES GET TIRED

FOCUS AND CONCENTRATION TAKE A BREAK

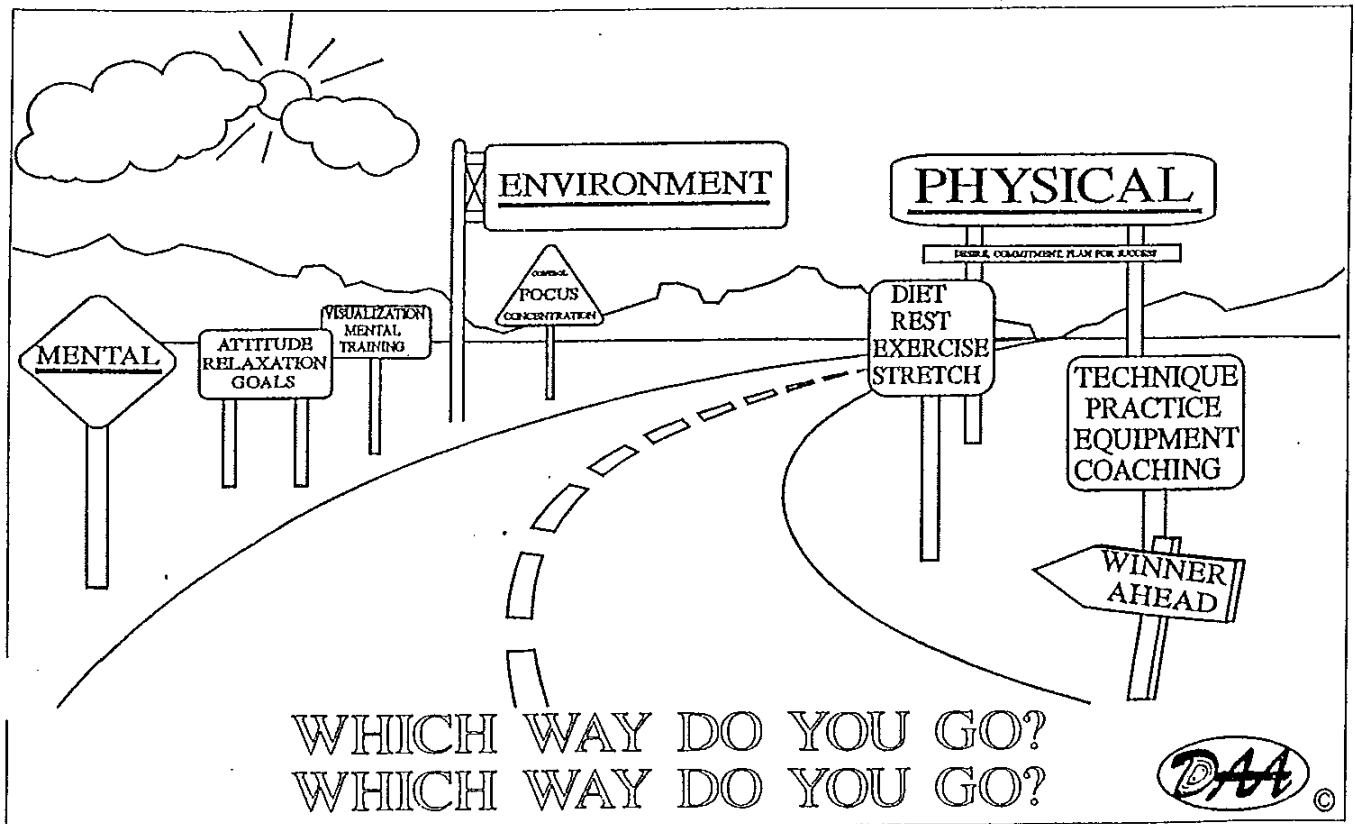
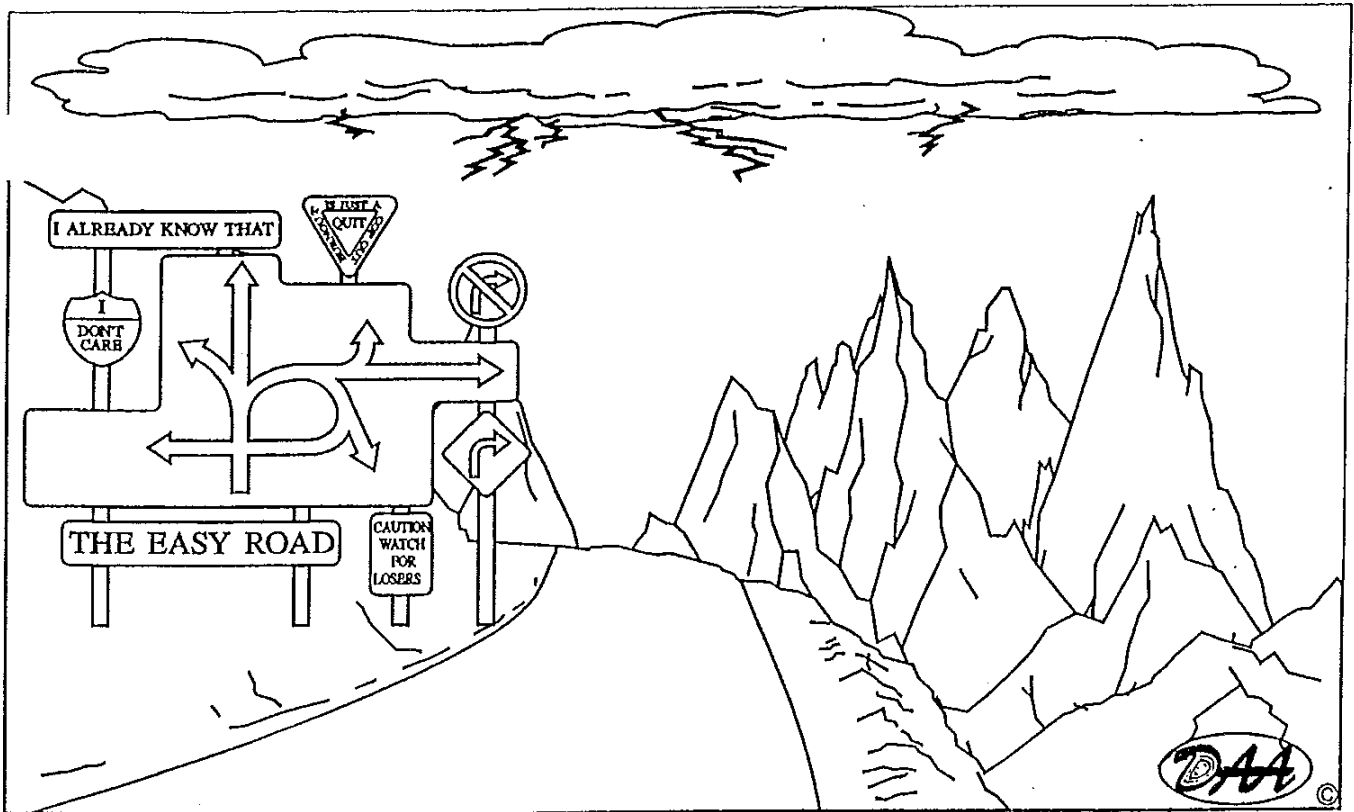

LEARN TO CALL YOUR SHOTS

WHAT IS "CALL YOUR SHOT"?

WHEN YOU FIRE A SHOT, YOU SHOULD BE ABLE TO TELL IF THE SHOT IS HIGH, LOW, LEFT OR RIGHT. AN EXPERIENCED SHOOTER CAN TELL YOU THE SHOT VALUE AS WELL AS WHERE IT IS WITHOUT LOOKING IN A SPOTTING SCOPE.

WHY YOU NEED TO CALL YOUR SHOTS?

ALL OF US WOULD LIKE TO BELIEVE THAT EVERY TIME WE PULL THE TRIGGER IT'S A PERFECT 10. UNTIL A NEW SHOOTER ACCEPTS THAT HE OR SHE IS THE ONLY REASON FOR AN IMPERFECT SHOT, IMPROVEMENT IS IMPOSSIBLE. WHEN A SHOOTER CALLS A SHOT HIGH, THEY CAN THEN START LOOKING FOR WAYS TO CORRECT THE NEXT SHOT. A SHOOTER WHO CAN'T CALL THEIR SHOTS HAS NO IDEA WHY THEY SEE A 5 WHEN THEY LOOK IN THE SPOTTING SCOPE. THE FIRST REACTION IS USUALLY TO BLAME THE AMMUNITION, THE GUN, THE WIND, OR ANYONE WHO HAPPENS TO BE WITHIN SIGHT. EVEN IF THE SHOOTER ACCEPTS THAT THEY CAUSED THE UNHAPPY SHOT. THEY CAN'T EVEN BEGIN TO CORRECT THE PROBLM OR ASK FOR HELP BECAUSE THEY DON'T KNOW WHERE THEY WERE SIGHTING WHEEN THE SHOT WENT OFF. A SHOOTER SHOULDN'T BEAT THEMSEL UP FOR AN OFF CENTER SHOT BUT SHOULD USE IT AS LESSON FOR MAKING FUTURE SHOTS BETTER.

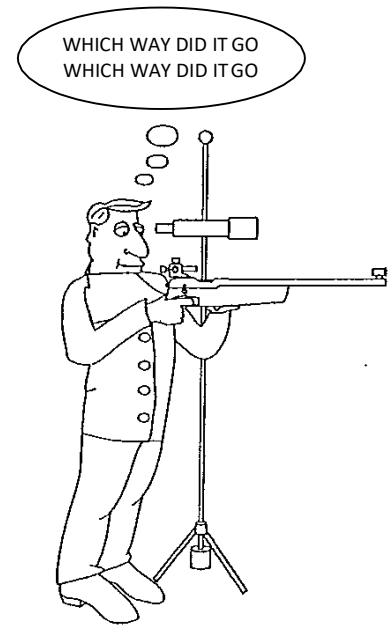

AT YOUR FINGERTIPS: An Exercise for Proper Sight Adjustment

By Kathie A. Powell
NRA Certified Instructor from Stratford, Conn.



It is very easy to tell your students to move their rear sight in the direction that they want the shots to go on the target. Oftentimes, however, they don't really understand. To make sure my students do understand me, I use my trusty fingers to illustrate this concept to both new and experienced shooters.

Adjusting Elevation

I explain the principle of sight adjustment in two phases. First, I demonstrate adjusting elevation (see Figure A). I have the students do the exercise along with me. We pretend that the index finger of the right hand is the front sight and the first two fingers of the left hand are the rear sight of an imaginary firearm.

They pretend that their "firearm" is Stationary and that the shots are high on the target (see Figure A-1). The students simulate moving the rear sight downward by moving the left hand down (see Figure A-2). This demonstrates the principle of moving the rear sight in the direction in which the shooter wants the shots to go on the target.

Following the principle of perfect sight alignment, the students pretend that they are preparing to fire another group of shots. In order to align the sights, the muzzle (front sight) has to be lowered (see Figure A-3). This exercise demonstrates to the students that lowering the muzzle is the direct result of having moved the rear sight down which will cause the shot placement to be lowered on the target.

Adjusting Windage

I explain adjusting windage in a similar manner (see Figure B).

The students pretend that their "firearm" is stationary and the shots are to the flight of the bullseye (see Figure B-1). They then simulate moving the rear sight to the left, since this is the direction in which they desire their shots to go (see Figure B-2).

By moving the rear sight to the left, the students have to move the muzzle (front sight) to the left in order to align the sights in preparation for firing the next group of shots (Figure B-3). This demonstrates that moving the muzzle to the left is the direct result of having moved the rear sight to the left which will cause the shot placement to be moved toward the left on the target.

Additional Pointers

You can then have your students do the exercise by themselves. Or you can have them demonstrate what to do when the shot placement is low on the target and what to do when the shot placement is to the left of the bullseye.

This exercise has worked well in helping all my students understand the principle of sight adjustment. It is also very safe for use in the classroom. I have yet to have a finger "go off" accidentally!

Sight Adjustment Training Aid

By HARRIS BERG

NRA Training Counselor

OBJECTIVE:

To demonstrate simply and easily how adjusting the rear sight on a firearm moves the point of impact (hits) on a target.

MATERIALS NEEDED:

(Note: Dimensions are not critical and can be altered. All lumber mentioned here is called 1" but is actually 3/4" thick.)

LUMBER:

- 1 piece 15" long x 5" wide
- 4 pieces 2" x 1-1/2"
- 2 pieces 2" x 5"
- 2 1/4" x 36" dowel stock

HARDWARE:

- 1 1/4" x 2" round head Slave bolt
- 1 1/4" nut washer
- 1 # 10 flathead wood screw
- 1 1/4" wingnut for stove bolt
- 2 5/16" nuts
- 1 5/16" (or 3/8") wood eye screw

MISCELLANEOUS:

1 piece 9" square or round sheet aluminum (1/8" tempered masonite can be used.)

A gallery match target (or equal), carpenter's glue, epoxy, wail paper paste (or equal) bright paint

TOOLS:

Drill press or electric 3/8" drill.
3/8", 1/4" and smaller size drill bits.
wood saw, screwdriver, scroll or saber saw, wood rasp., pencil and sandpaper

DIRECTIONS FOR MAKING & ASSEMBLING

(Note: All holes are to be drilled 1/4" diameter, unless another size is specified.)

The 15" x 5" piece represents a firearm and is cut into a shape somewhat like a tennis racquet using the scroll or saber saw. The "head" of the racquet is approximately 4-1/2" wide by 5-1/2" long, then tapers to a "handle." 1" x 2" wide and about 9" long. The edges of the head are rounded.

Drill a hole 3" to 4" deep in the center of the 1" x 2" end of the 9-inch handle in a straight direction, parallel to its length. If a drill press is not available drill a hole through two of the four pieces of 2" x 1-1/2" wood blocks. Cut an 18" piece from one of the 36" dowels. Taper each end slightly and insert through the holes in the two small blocks. Place the blocks about 4" from end to end on the dowel. Center the blocks from side to side on the 2" x 9" handle and glue them to the end of the handle of the racquet. (The dowel rod should be removable and not glued into the blocks.) Be sure the dowel is parallel to the 9" handle and centered from side to side. Clamp the blocks so they do not move and let the glue set. The outer end of the dowel should be painted. (The painted end of the dowel represents a point of impact of a bullet on the target.)

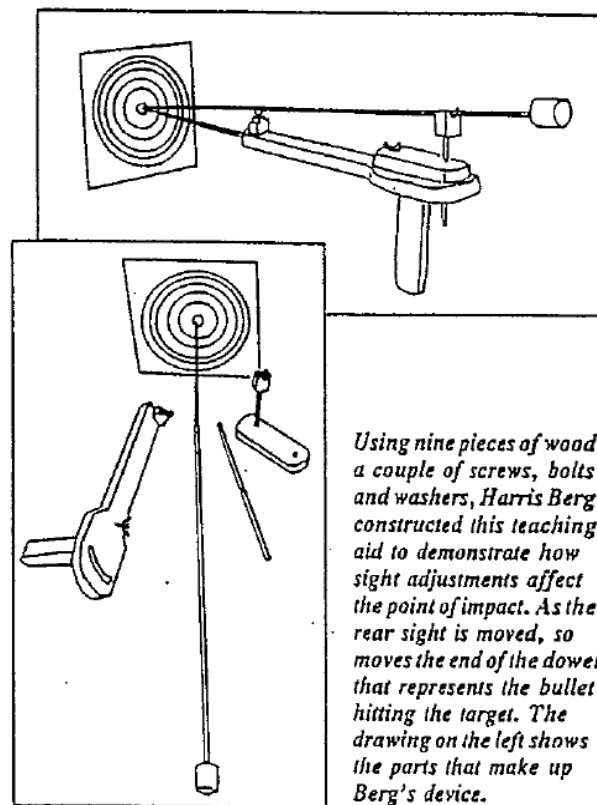

Using nine pieces of wood, a couple of screws, bolts and washers, Harris Berg constructed this teaching aid to demonstrate how sight adjustments affect the point of impact. As the rear sight is moved, so moves the end of the dowel that represents the bullet hitting the target. The drawing on the left shows the parts that make up Berg's device.

Center one of the 2" x 5" pieces on the head of the racquet, parallel to its length with the front end about even with the part where the taper to the 2" handle starts. The rear of the 5" piece should be near the top of the head. After the 5" block is centered on the head of the racquet, clamp together and mark a spot in the center of the 2" width, about 3/4" from the front end and drill through both pieces. These two pieces will be held together at this point by the 1/4" x 2" stove bolt, washer and wingnut and will be the pivot point for the 5" block, which will represent "windage" adjustment. When assembled, the farther end will move from side to side to demonstrate rear sight windage adjustment.

A 1/4" hole should be drilled at the other end of the 5" piece in the exact center of the 2" width, about 3/4" from its end. With the bolt, washer and wingnut through the front hole of the 5" block holding it to the head, put a pencil in the rear of the hole, pivot the 5" piece and draw an arc on the head, stopping about 1/2" from the end of each side. Then use the saber or scroll saw to cut a 3/8" wide arc as drawn, so that when a length of 1/4" dowel is pushed through the 1/4" hole in the 5" block and through the 3/8" arc cut into the head below the dowel will be able to move freely from side to side through the cut out radius of the arc and at the same time move freely up and down through to the bottom side of the head.

For a grip, the second 5" block should be glued on its end to the bottom of the head and secured from the outside top of the head with the flathead wood screw".

Basic Rifle For the Dumbfounded

**A guide for new and
inexperienced 4-H shooting sports
leaders on the basic elements of
teaching the Rifle discipline.**

by Terry Abbott
4-H Lead Rifle Instructor
National Shooting Sports Training Team
4/22/2009

Rules and caveats for using this Guide

- You must be a certified leader to teach any of the shooting disciplines
- This guide is a supplement to the 4-H rifle discipline manual not a replacement for it.
- Read and refer to your 4-H rifle discipline manual to gain a better understanding of
- The concepts outlined in this guide.
- The attention span of your students will dictate how much can be covered in one lesson. Typically, the younger the age group the shorter the lesson.

This guide is an attempt to boil down rifle instruction to the most basic concepts. The goal is to assist the novice instructor in teaching safe and correct techniques for rifle shooting. Basic concepts taught correctly are far better than more complex lessons taught poorly. As you gain more knowledge and experience as an instructor your confidence in teaching more advanced concepts will grow. Remember, the basic 4-H goal is youth development. You do not have to be an Olympic class coach in rifle to run a successful program.

Safety First

A brief discussion of the Safety Rules should occur at the beginning of every meeting or event. This will indicate to all that safety is taken seriously and get everyone thinking about it. Repetition of the safety rules also ingrains them into the participants and they eventually become a habit.

- **MAT** - A simple reminder for the 3 primary safety rules that is easily memorized. Just make sure that students fully understand the meaning and are not just parroting it back.
 - MUZZLE in a safe direction.
 - ACTION open.
 - Finger off the TRIGGER until ready to shoot.
- **Range Commands** - Commands can vary from location to location but are similar in purpose. Whatever list of commands selected should be used consistently to avoid confusion.
- **Responsibility** - Be clear that everybody is responsible for safety. Reward good safety practices and reinforce the idea that anyone can call cease fire if an unsafe situation arises.

Basic Teaching

If you've been through a National or State Training workshop you will have acquired a lot of detailed information about rifle shooting. Don't feel you have to pass on every tiny detail to your students in the first lesson. This is a common mistake with new instructors. You as an instructor should be knowledgeable of the finer points or at least know where you can find the information. However, most of your students just want to shoot. Your job is to get them shooting as soon as possible within the limits of good safety practices. Don't bore your students with long lectures. They will not remember most of it anyway.

- Your presentation should be appropriate to the age group.
- Keep your instruction in short easy to remember segments.
- Make sure your students understand the terminology.
- Give your students just enough information to accomplish the immediate exercise.
- Review and **repeat** the key pieces of information often.
- Have a goal of two or three things you want your students to learn.

Basic Teaching Continued

Tell'm what you're gonna tell'm - Tell'm - Tell'm what you told'm

For the first lesson I recommend having everything set up so that you can get your students shooting ASAP. Shooting is what they came for. You can get them involved in setting up the range and equipment care in future meetings. Get them hooked first.

Example First Lesson:

Instructor: "Before we begin there are some important things we all need to understand. They are the parts of the rifle, the safety rules and the range commands."

Briefly explain the basic parts and what they do. Barrel/Muzzle, Action/Trigger, Stock, Sights. Emphasize the importance of the muzzle and trigger. SAFELY demonstrate how the action works. Explain how the sights should be aligned. NRA has some excellent posters for the different types. Review and ask for feedback.

Briefly explain the safety rules that apply to this lesson. Since you should be shooting off the bench, for the first lesson the rules are simple. Keep the muzzle pointed down range. Keep your finger off the trigger until ready to fire. Do not handle guns when others are down range. Obey all range commands immediately. Review and ask for feedback.

Briefly explain the Range Commands. It's a good idea to have a poster with the range commands posted wall tile wall near the firing line. This will help you and others to remember and use the commands consistently. Make sure they understand anyone can call a cease fire. Review and ask for feedback.

Basic Teaching Continued

If you are properly prepared it shouldn't take any longer than 15 or 20 minutes to get your students shooting. Remember, young people have a short attention span. Once you have them shooting for awhile you can stop and give them another 15 minute chunk of information.

First, praise them for the things they are doing right. Make sure it is legitimate, not false praise. It may be something different for each individual but there will always be something.

Make it easy for your students to succeed. Start with a sight alignment exercise by having them shoot at a blank piece of paper. The back of a target works well. This will encourage them to focus on the sights. If they can keep all shots in a 4 inch circle or less then they understand sight alignment. When you introduce a target I recommend the TQ-18 training target. It has a small black area but the scoring rings go all the way to the edge of the target. This provides a 6 inch diameter scoring area. If your students understand sight alignment they will score on this target and it will build confidence. The regulation air rifle target, by contrast, is only about 1.5 inches in diameter and the beginner may not score on this target. Not scoring is no fun! The regulation distance to the target is 33 feet. There is nothing wrong with starting at 25 feet to insure initial success.

Another thing that must be considered is the capability of the equipment. If your rifles will shoot no better than 1 inch groups at 33 feet then using a regulation target is ridiculous. Shoot at bigger targets.

Sights

Front and rear sights in proper alignment.

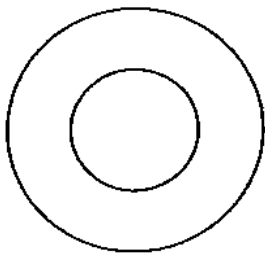

Peep Sights

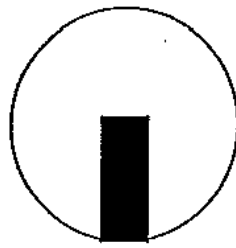

Peep and Post

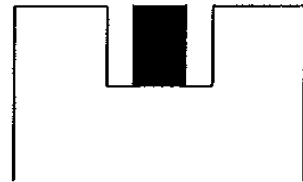

Open Sights

Trouble Shooting

- Once your students start shooting, observe them carefully for basic errors. Safety errors must be corrected immediately. Shooting errors should be corrected one at a time. If a student is doing four things wrong don't try to fix them all at once. You will just confuse and frustrate the shooter.
- The two most common safety violations you will see are FINGER ON THE TRIGGER BEFORE READY TO SHOOT and POOR MUZZLE CONTROL. Fix these errors immediately and remind your shooters often about proper safety practices.
- Remember, 4-H is learning by doing. Give them a chance to learn on their own and enjoy shooting. When you do make a correction be positive and brief with your instruction.
- After your session is over allow a few minutes to debrief. Talk to your students about what they learned. Find out what they liked most about the session. This feedback will reinforce the lesson and it will also give you a clue if you accomplished your goal.
- Make a few notes on changes you may want to make for your next session while they are fresh in your mind.
- Inevitably you will make mistakes. If you aren't making a mistake now and then you probably aren't doing much. Instructing is a lifetime learning process. Learn from your errors and try to do better next time. Nobody is born an expert instructor. You are in 4-H and you are learning by doing too.

Summary

This document is intended to provide some hints on teaching and demonstrate one approach to a basic first session for new shooting sports leaders. Additional lessons can be developed using a similar format. This is not the only way to do things. Feel free to use your imagination and develop your own style of presenting the rifle discipline material. However, I do feel that there are basic tenants for successful teaching that should not be ignored. You will notice that stress the importance of brevity numerous times. In my opinion this is not an option. Nothing turns off a kid quicker than a long drawn out lecture. Even when teaching adults you will have much greater success if your lesson is broken down into small segments of simple instruction and then doing the activity.

Shooting Sports is truly an activity for a lifetime and it's a great way to carry the mission of youth development to young people. Good luck and thanks for your effort.